

# FLARE See Through 100 Outdoor

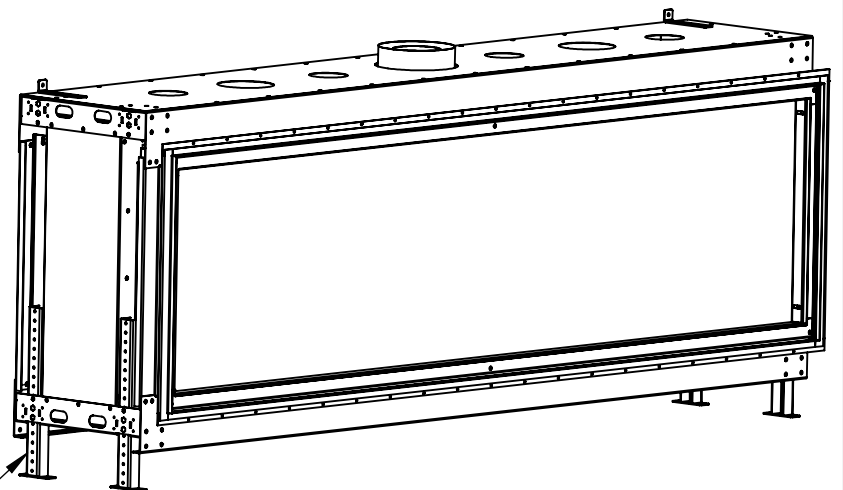
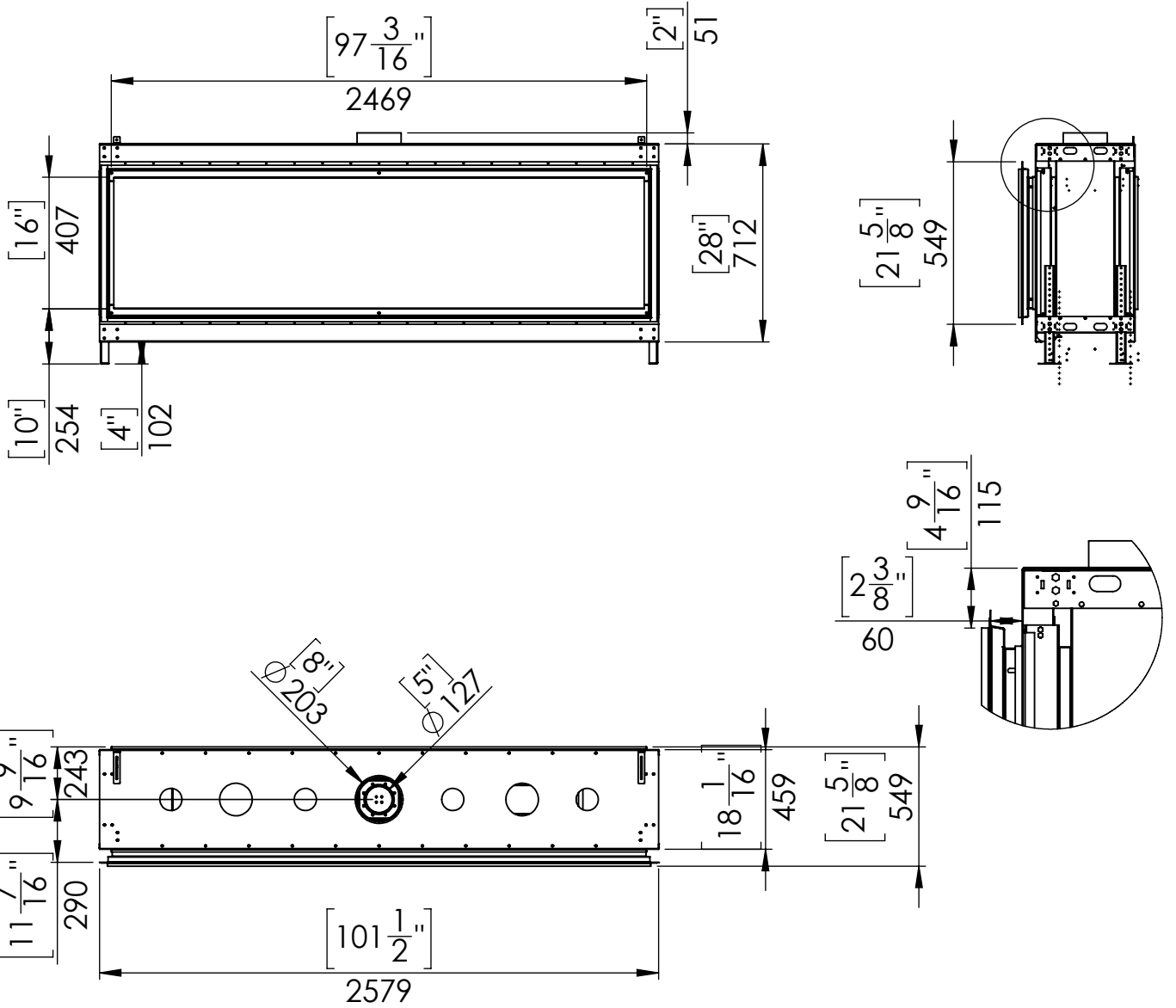

Telescopic legs ranges (from bottom of glass): 10"-19"

## Flat installtion - option 1

## Recess installtion - option 1

Metal studs **surrounding all sides** of Fireplace

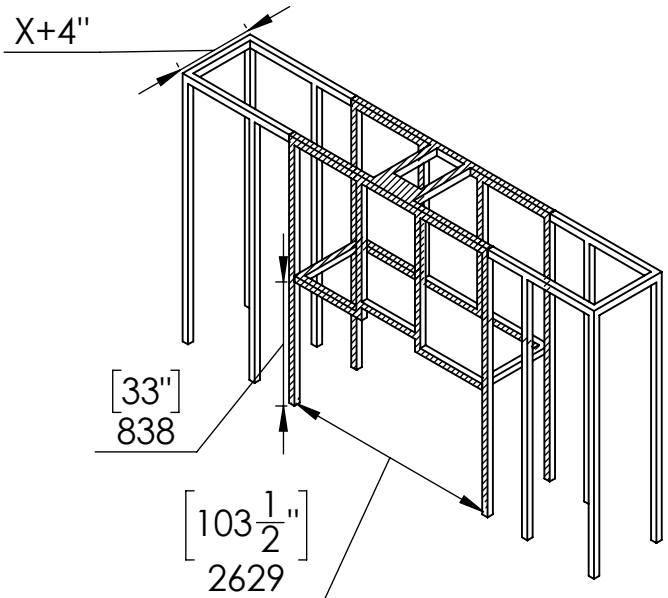
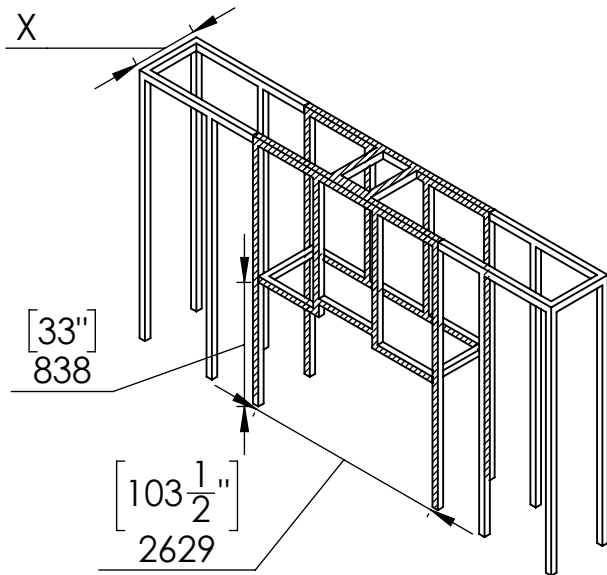

▨ Metal stud

▨ Metal stud

## Flat installtion - option 2

## Recess installtion - option 2

Metal studs **above** the Fireplace **only**

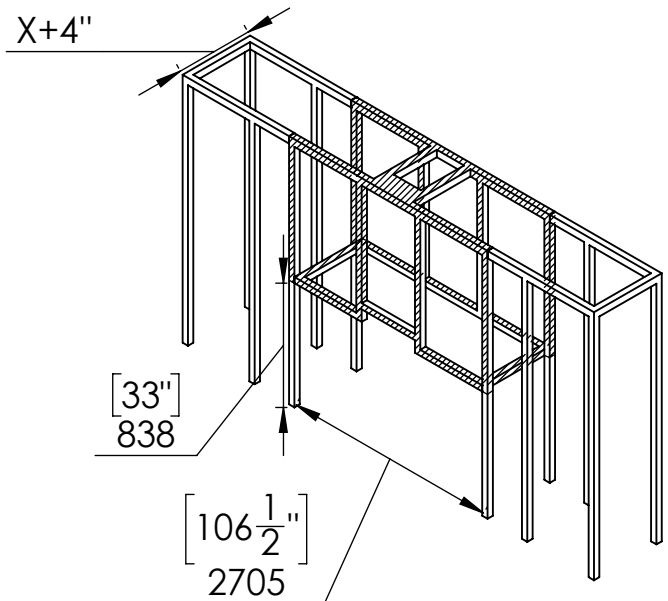
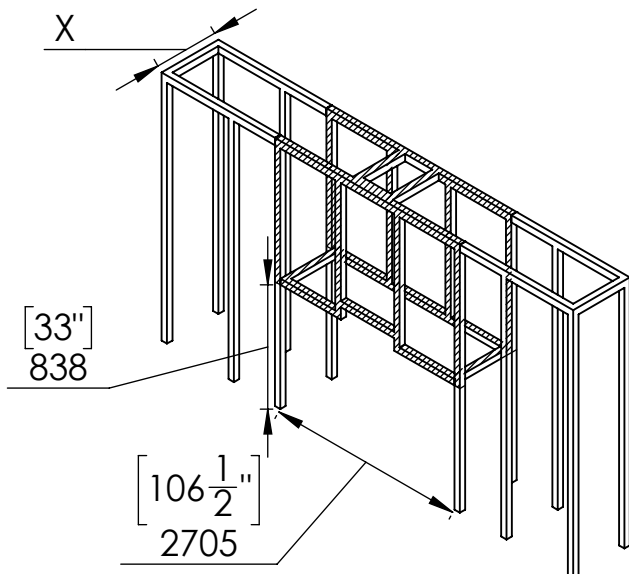

▨ Metal stud  
□ Coverd Wood stud

▨ Metal stud  
□ Coverd Wood stud

## External Cement Board Opening

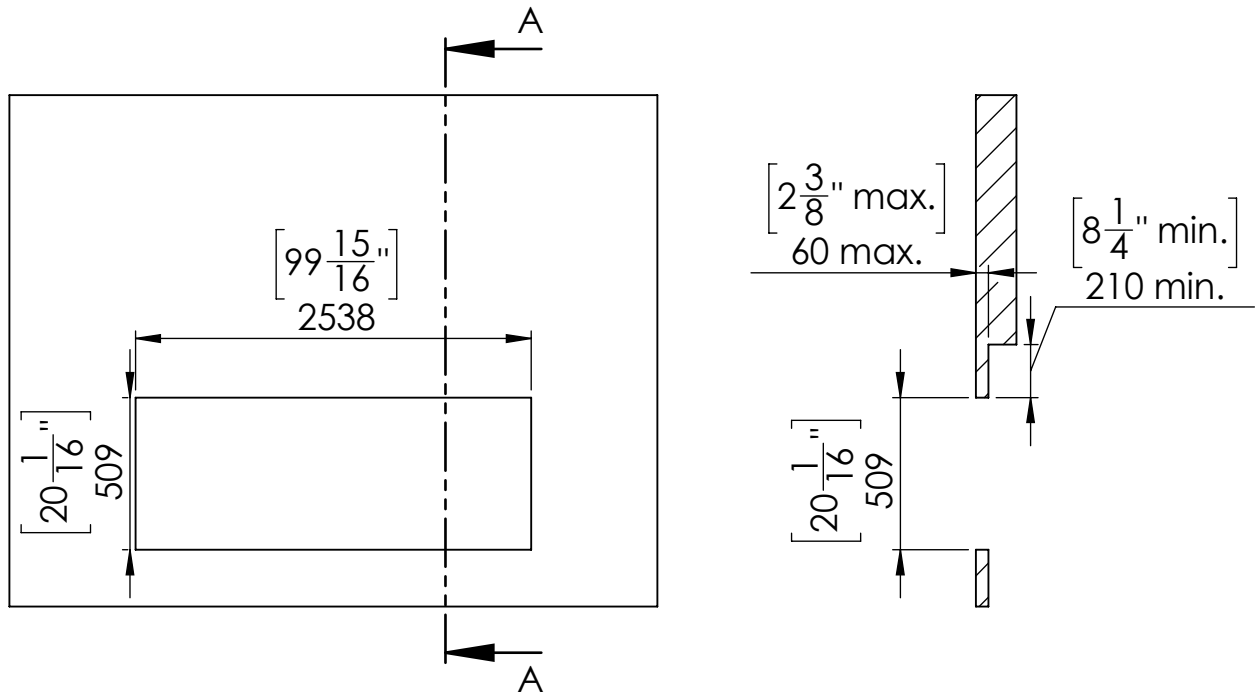

## Outdoor Kit - External Frame

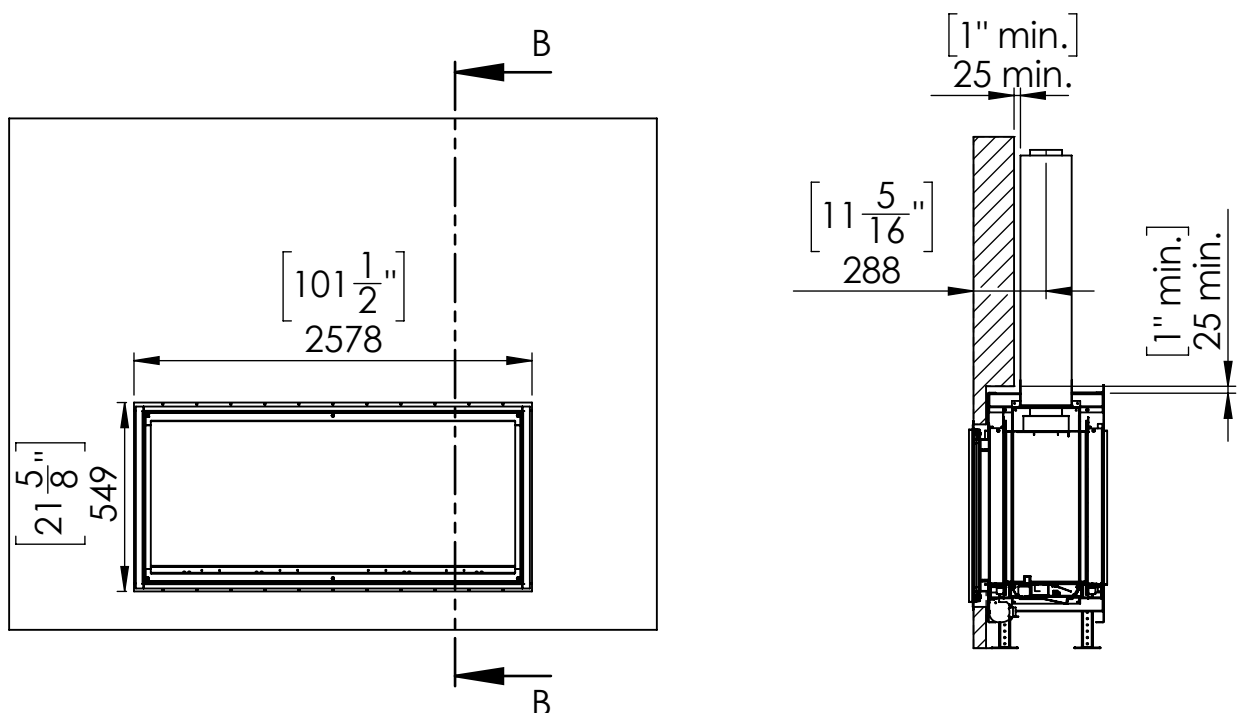

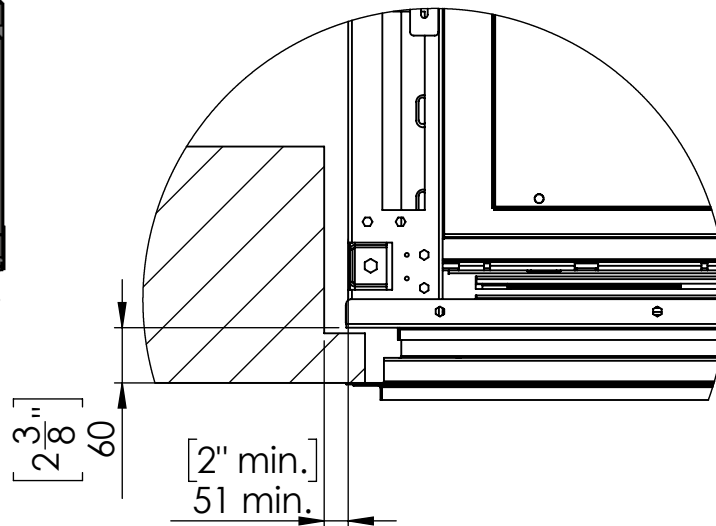
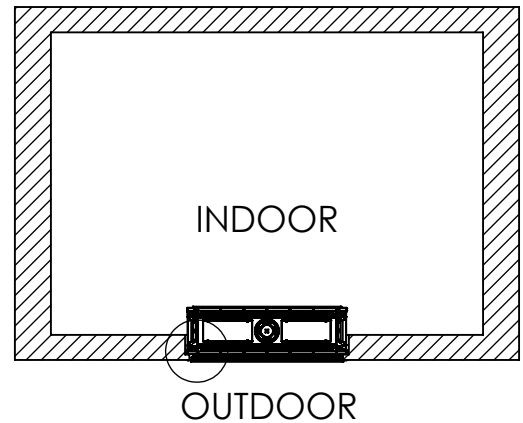
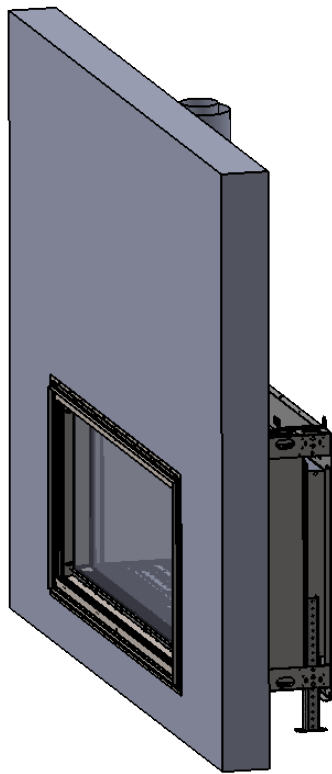

## Specifications for Appliance Flare See Through 100

Factor	NG	LPG
Burner Type	55,105,55	55,105,55
Orifice	550,1200,550	180,260,180
BTU Max.	60000	60000
BTU min.	32500	25500
Kw/h	17.5k	17.5k
Chimney DIA.	5X8	5X8
Manifold Pressure[w.c]	4.4	7.4
Efficiency rate	81	76
Glass Size Length\Width	2520.5 X 420 mm	99" 1/4 X 16" 8/16'
Appliance Weigh	270Kg	595lb