

FRONT DIMENSIONS

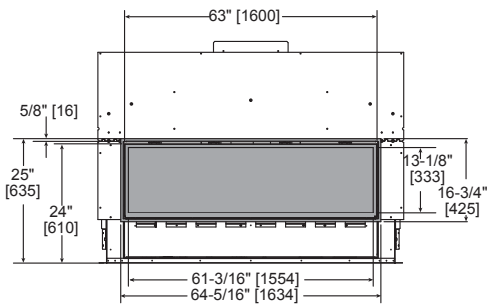

Clean Face Trim

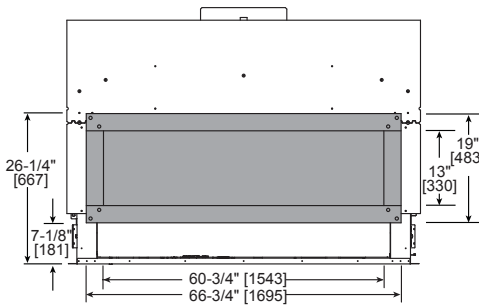

Loft Forge Front

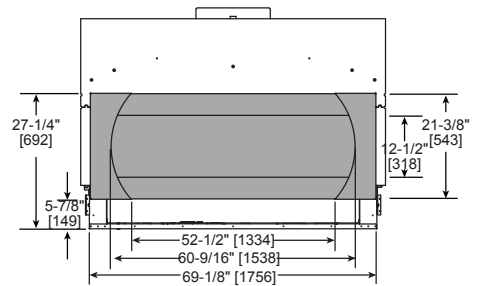

Quattro Front

- Rectangular holes on bottom of access panel should be covered.
- Approved for 0"-4" finishing material on inside fit method
- If finishing materials are 0"-1" thick, the outer trim ring should be adjusted out so that the trim ring overlaps the finishing material. This is intended to provide the cleanest look.
- If finishing materials are 1-4" thick, install the trim ring all the way in. Finishing materials may not extend past the outside edge of the trim ring.

- Rectangular holes on bottom of access panel must be exposed.
- ONLY approved for 0"-1" finishing material on overlap fit method

- Rectangular holes on bottom of access panel must be exposed.
- ONLY approved for 0"-1" finishing material on overlap fit method

FINISHED OPENING DIMENSIONS

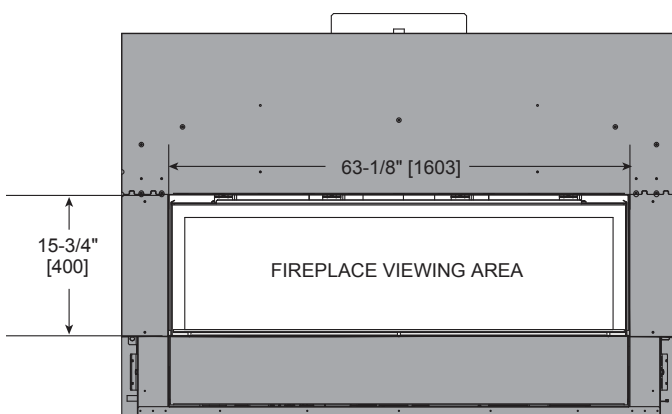

Inside Fit Method
(Clean Face Trim)

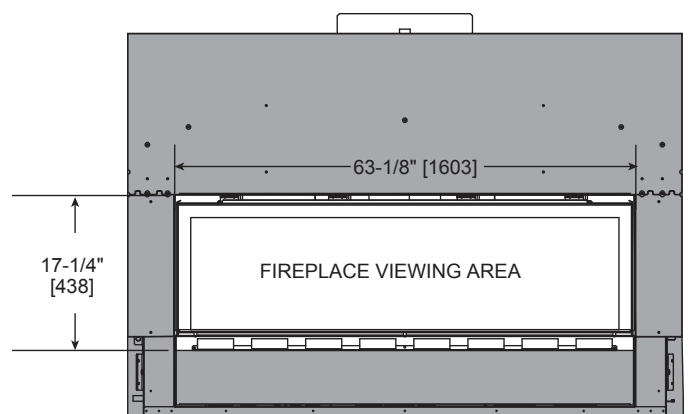

Overlap Fit Method
(Loft Forge, Quattro)

APPLIANCE LOCATION

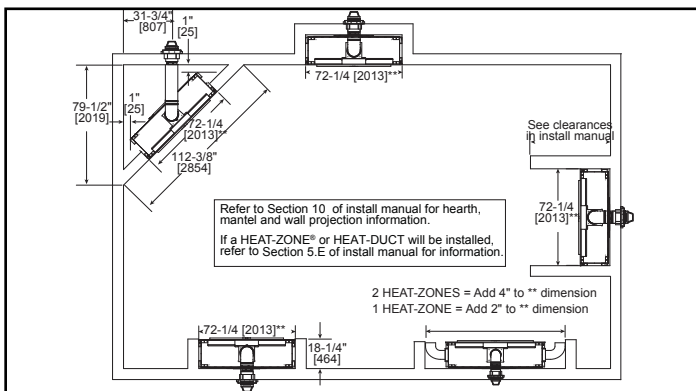

FRAMING DIMENSION

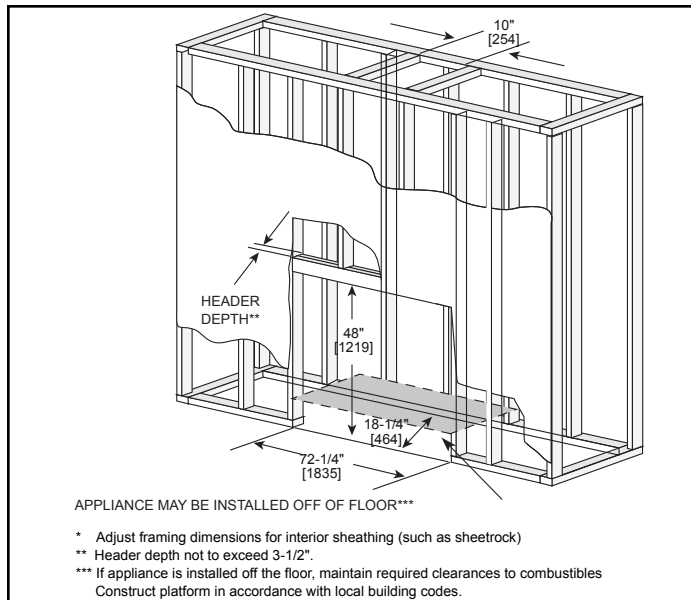

WALL PENETRATION

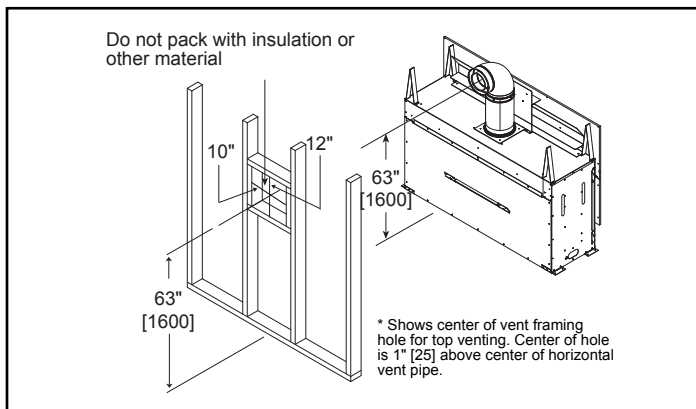

CLEARANCES TO COMBUSTIBLES

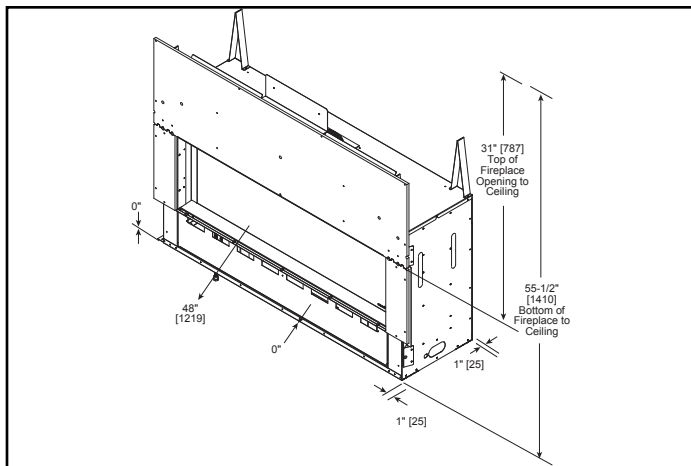

MANTEL PROJECTIONS - COMBUSTIBLE

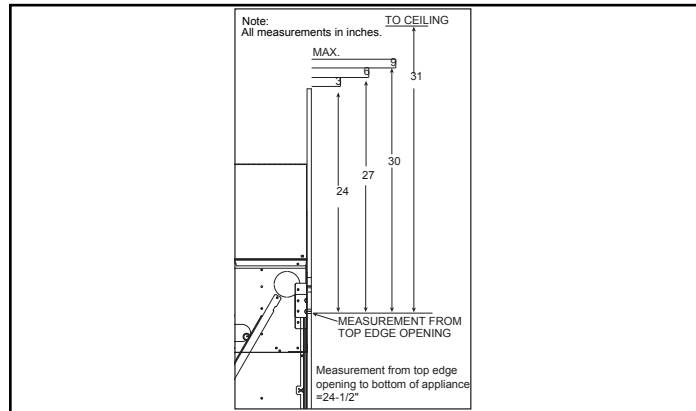

MANTEL LEG/WALL PROJECTIONS

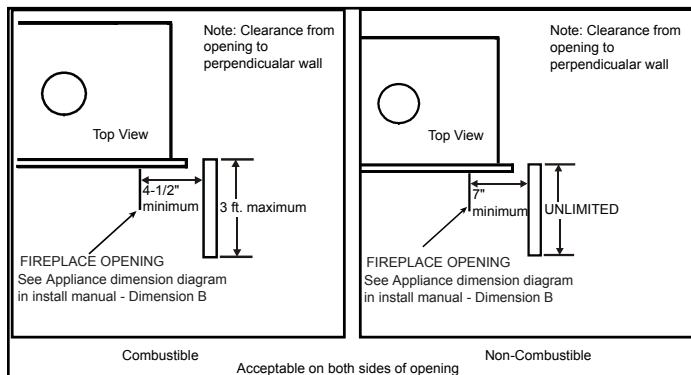

MANTEL PROJECTIONS - NON-COMBUSTIBLE

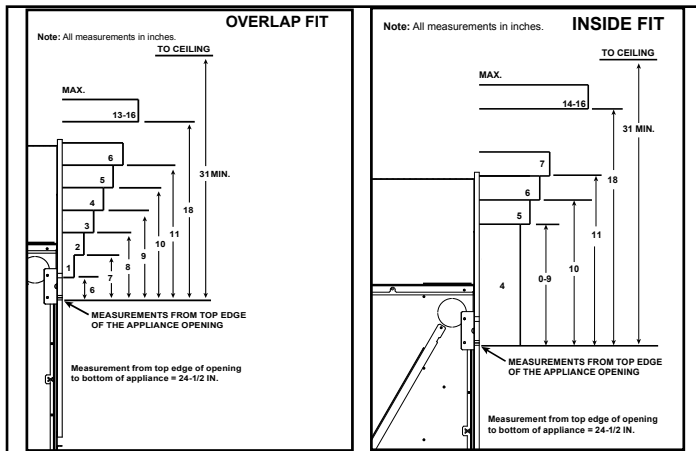

PRODUCT LISTING CODES	
US	ANSI Z21.88-2014
CAN	CSA 2.33-2014
	UL307B

Product information provided is not complete and is subject to change without notice. Product installation must adhere strictly to instructions accompanying product to avoid risk of fire and potential injury.

Additional information can be found online at www.heatnglo.com