



Applications
 Indoor
 Natural Gas • LP
 Combustible Floor Installation
 Custom Finish
 Isokern DM Chimney
 Steel Chimney

Firebrick Patterns
 Herringbone • Stock Bond
 Basket Weave • Running Bond

Firebrick Options
 Square Edged Fulls - Red/Beige
 Square Edged Splits - Red/Beige
 Tumbled Splits - Red/Beige
 Square Edged Soaps - Red/Beige



THE ISOKERN B-VENT IBV SERIES (GAS ONLY)

The warm embrace of fire has captivated human beings since the dawn of time. Today, Isokern can help give your home fire an inspired look worthy of 21st century amazement. The only field-assembled, modular refractory, decorative gas appliance in the market today, the Isokern B-Vent IBV Series has the largest finished opening height of 52" and can be installed directly onto combustible floor systems, while meeting ANSI Z21.50 standard guidelines. With our proprietary quick start firing system, the Isokern IBV comes complete and includes our exclusive Isoflames Stadium Burner electronic ignition gas log set. Isokern's newest log set, the Stadium Burner, has a convenient all Remote Electronic Ignition with an optional wall switch. This reversible set also gives the homeowner two presentation options: oak and split oak.

THE B-VENT (IBV) SERIES

Assembled Firebox and Smoke Dome Dimensions 36, 42, 46

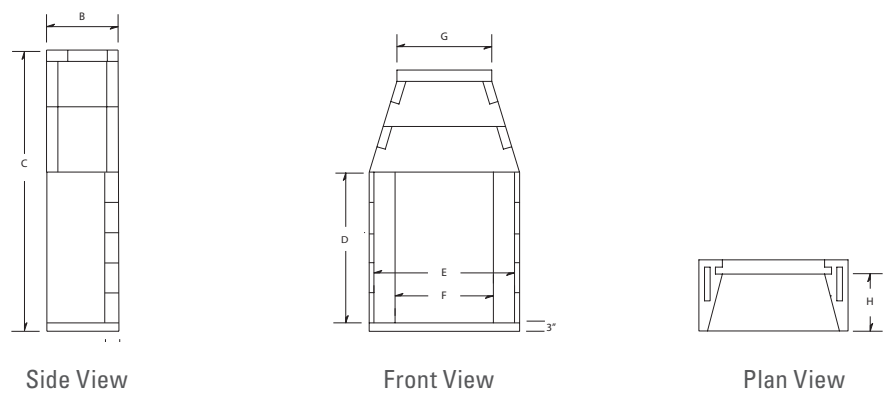

| Model | A | B | C | D | E | F | G | H | I | Minimum Framing | Weight |
|---|-----|---------|---------|----------|---------|---------|---------|---------|----|-------------------------------------|----------|
| 36 | 43" | 25 1/4" | 71 1/4" | 31 1/2" | 36 1/8" | 27 1/4" | 21 1/2" | 20 1/4" | 5" | (43" w) x (71 1/4" h) x (26 3/4" d) | 1500 lbs |
| 46 | 53" | 25 1/4" | 71 1/4" | *31 1/2" | 47 1/8" | 37 1/4" | 32" | 20 1/4" | 5" | (53" w) x (71 1/4" h) x (26 3/4" d) | 1700 lbs |
| *To achieve height dimension "d" in table above, a 100" (8.3') minimum flue height with 10" I.D. B-Vent is required | | | | | | | | | | | |
| 36 | 43" | 25 1/4" | 81 3/4" | *42" | 36 1/8" | 27 1/4" | 21 1/2" | 20 1/4" | 5" | (43" w) x (81 3/4" h) x (26 3/4" d) | 1650 lbs |
| 46 | 53" | 25 1/4" | 81 3/4" | *42" | 47 1/8" | 37 1/4" | 32" | 20 1/4" | 5" | (53" w) x (81 3/4" h) x (26 3/4" d) | 1850 lbs |
| *To achieve height dimension "d" in table above, a 9' minimum flue height with 10" I.D. B-Vent is required | | | | | | | | | | | |
| 36 | 43" | 25 1/4" | 92 1/4" | *52 1/2" | 36 1/8" | 27 1/4" | 21 1/2" | 20 1/4" | 5" | (43" w) x (92 1/4" h) x (26 3/4" d) | 1800 lbs |
| 46 | 53" | 25 1/4" | 92 1/4" | *52 1/2" | 47 1/8" | 37 1/4" | 32" | 20 1/4" | 5" | (53" w) x (92 1/4" h) x (26 3/4" d) | 2000 lbs |

*To achieve height dimension "D" in table above, a 12' minimum flue height with 10" I.D. B-Vent is required