

ISOKERN B-VENT FIREPLACE
A PRODUCT OF EARTHCORE INDUSTRIES, LLC.
INSTALLATION, OPERATION, MAINTENANCE and
OWNER'S MANUAL

ISOKERN MODELS IBV-36 and IBV-46

IMPORTANT: This manual contains assembly rules, installation steps and guidelines, and use and maintenance instructions for Isokern B-VENT gas appliances (IBV). This manual must become the property of and be reviewed by all current and future users of this product. It is the responsibility of the distributor, general contractor and the installer of this product that the instructions in this manual are followed exactly and, further that the allowed gas log appliance used in this product be installed in strict accordance with the gas log manufacturer's listing and explicit installation and operation instructions.

**This Listed Top Vented Gas Log Enclosure is
designed for use with Decorative Natural Gas or
Propane (LP) Gas Appliances, only.**

WARNING: If the information in this manual is not followed exactly, a fire or explosion may result causing property damage, personal injury or loss of life.

- Do not store or use gasoline or any other flammable vapors or liquids in the vicinity of this or any other appliance.

- WHAT TO DO IF YOU SMELL GAS:

- * Do not try to light any appliance.
- * Do not touch any electrical switch.
- * Do not use any phone in your building.
- * Immediately call your gas supplier from a neighbor's phone. Follow the gas supplier's instructions.
- * If you cannot reach your gas supplier, call the fire department.

- NOT FOR USE WITH SOLID FUEL.
- The flue damper must be in the full open position when burning the gas logs.

-This appliance complies with National Safety and is tested and listed to ANSI Z21.50b - 2009 as vented gas fireplaces.
- Installation and service must be performed by a locally certified gas service agent, licensed plumber or the gas supplier.
-Installation must conform to local codes. Check local codes prior to installation.
In the absence of local codes, installation must conform with current National Fuel Gas Code, ANSI Z223.1.

INSTALLER: Leave this manual with the appliance.
CONSUMER: Retain this manual for future reference.



PFS Report No. 09-79

SAP No. 506022-03

© 2009 ECI

Issued: May, 2011

Revision: 003

THIS MANUAL CAN ONLY BE REPRODUCED IN ITS ENTIRETY

Table of Contents

General Information	3
Safety Information	4-5
Assembled Firebox and Smoke Dome Dimensions.....	6
Component List and Dimensions.....	7
Required Component List	8
Required Clearance to Combustibles	9
Combustible Floor System Loading	10
IBV Rough Framing Dimension & Corner Location Layout	11
IBV Assembly Instructions	12-18
Raised and Flush Hearth	13
Access Modifications	16
Fire Brick Installation	17
Metal Canopy Installation	18
Venting Installation	19-21
Anchor Plate Installation	19
Flush Wall Finish Detail	22
Required Clearances (when sheathing protrudes beyond front of firebox)	23
Flush Wall Fire Brick Finish Detail	24
Finish Facing Detail	25
Interior Full Masonry Veneer Finished Fireplace Fronts	26
Interior Full Masonry Veneer Finished Fireplace Fronts Details	27
Noncombustible Finished Facing Requirements & Clearance to Combustible Trim	28
IBV Pilot Assembly Wiring Diagram	29
ISOFLAMES Gas Log System Owners Manual	30-38
General Information	31
Safety Instruction Prior to Installation	31-32
Gas Log Burner Installation	33-34
ISOFLAMES Gas Log Assembly Instructions.....	35-36
Safety Instruction Before Lighting & Lighting Instructions	37-38
Troubleshooting & Maintenance	39
Customer Service & Warranty	40
Warranty Card	41
Optional Iso-Flame Wall Switch Instructions.....	42
Notes	43
Warranty	

Note: Illustrations shown in this manual are not to scale and are intended to show “typical” installations. Nominal dimensions are given for design and framing reference only since actual installations may vary due to job specific design preferences. However, always maintain minimum clearances to combustible materials and do not violate any specific installation requirements.

General Information

IBV Models IBV-36 and IBV-46 are tested and listed by PFS Corp., USA Report No. 09-79 to ANSI Z21.50b-2009b-2009. The IBV models are top-vented, gas only fireplaces that are listed for use only with the ISOFLAMES Gas Log appliance listed in this installation manual. These gas appliances come with a gas control valve that includes an automatic shut-off switch. The gas valve is available in a millivolt remote control pilot assembly.

The exhaust flue gases are to be vented through the top of the unit with listed B-Vent piping. A ten inch (10") diameter, double wall B-Venting system and a listed vent cap are not supplied but are required for proper operation of all IBV Models, 36 and 46. See venting instructions on pages 19-21.

WARNING: This gas appliance must not be connected to a chimney flue servicing a solid fuel burning appliance.

Intended Use Statement:

The IBV is intended to burn propane (LP) gas or natural gas (NG), only. This appliance is not intended to be used as a primary source of heat.

The IBV and its approved components are safe when installed according to this installation manual and when operated as recommended by the manufacturer. Unless you use Earthcore Industries, LLC approved components tested for this appliance, you may cause a fire hazard or serious injury.

Before you begin the installation of this appliance, read these instructions completely.

Earthcore Industries, LLC disclaims any responsibility for the following actions:

1. Modification of the appliance or any of its components.
2. Use of any component part not approved by Earthcore Industries, LLC in combination with this appliance.
3. Installation or operation in a manner other than instructed in this manual.
4. Burning of anything other than the listed gas log unit and the type of gas approved for use in this gas appliance.

Notes:

The most important areas of concern with the installation of the top venting IBV are clearance to combustible materials, proper assembly of component parts, load carrying capacity of underlying floor system, height of chimney system, hearth extensions and the techniques employed in applying finishing materials to the wall surrounding the IBV.

Each of these topics will be covered in detail throughout this manual. Special attention must be given to each topic as the installation progresses.

The installation of the IBV must conform with local codes or, in the absence of local codes, with the current National Fuel Gas Code, ANSI-Z223.1/NFPA 54 or the current Natural Gas and Propane Installation Code, CSA B149.1.

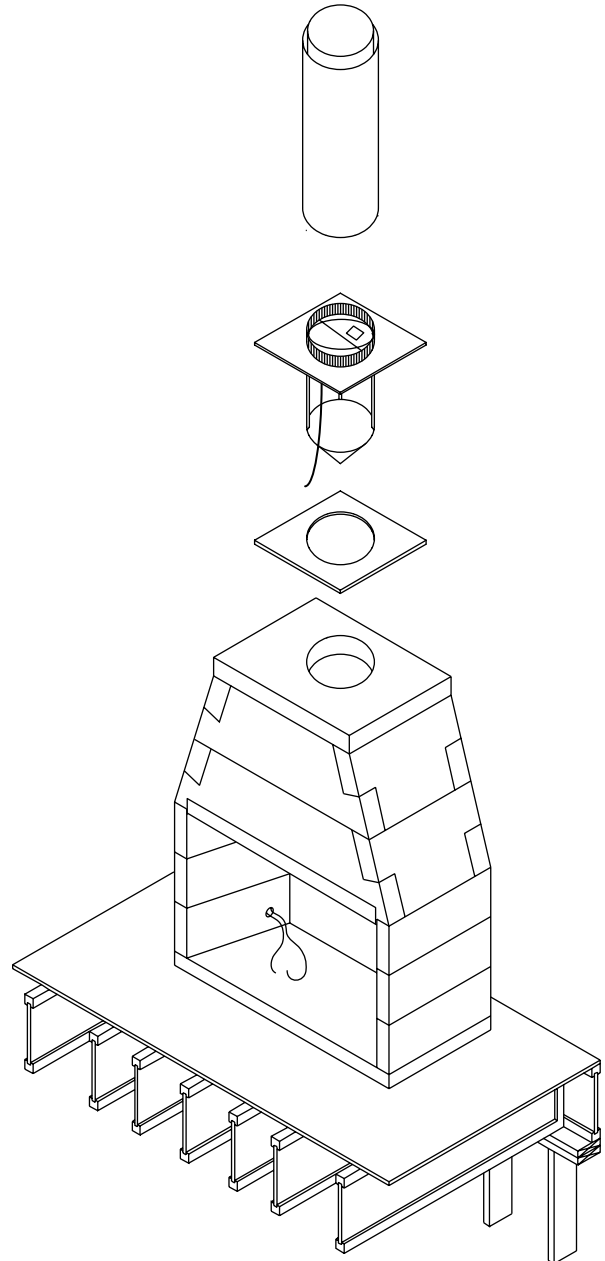

Safety Information

WARNING: This product contains or generates chemicals known to the state of California to cause cancer or birth defects or other reproductive harm.

Important: Read this owner's manual carefully and completely before trying to assemble, operate or service this fireplace. Improper use of this fireplace can cause serious injury or death from fire, burns, explosions and carbon monoxide poisoning.

CAUTION: Carbon monoxide poisoning may lead to death!

This fireplace is a vented product and will not produce any gas leakage into your home if properly installed by a qualified service person. If this unit is not properly installed by a qualified service person, gas leakage may occur.

Propane (LP) gas and natural gas (NG) are both colorless and odorless gases. An odor-making agent is added to each of these gases to help you detect a gas leak. However, the odor added to these gases can fade and gas may be present even though no odor exists.

Carbon Monoxide Poisoning: Early signs of carbon monoxide poisoning resemble flu symptoms, including headaches, dizziness or nausea. If you have these signs the fireplace may not have been installed properly, get fresh air at once! Have the fireplace inspected and serviced by a qualified service person or your gas supplier. Some people are more affected by carbon monoxide than others. These include pregnant women, people with heart or lung diseases or anemia, people at high altitude or under the influence of alcohol. Earthcore Industries, LLC strongly recommends the use of a carbon monoxide detector/ alarm device wherever gas fired appliances are in use.

All parties either involved in or associated with the installation, service and use of this fireplace must read this entire manual. Keep this manual for reference and as a guide book to safe operation of this fireplace.

WARNING: This unit is not for use with solid fuel.

1. Always check local building codes governing fireplaces and fireplace installations. The IBV installation must comply with all local, regional, state and national codes and regulations.
2. The B-Vent chimney system is for top venting only and must vent vertically through the roof of the building.
3. The IBV unit is listed for use with the ISOFLAMES decorative gas log appliance listed in this manual only.
4. This appliance is only for use with the type of gas indicated on the rating plate. This appliance is not convertible for use with other gases.
5. For propane (LP) use do not place propane supply tank(s) inside any structure. Locate propane supply tank(s) outdoors.

To prevent performance problems, do not use propane fuel tank of less than 100 lbs. capacity.

6. Do not install the IBV in a mobile home or recreational vehicle.

Note: Never install where curtains, furniture or other flammable objects are less than forty-eight inches (48") from the front of the fireplace opening.

7. Do not install the IBV in high traffic areas or in windy or drafty areas.

8. This fireplace reaches high temperature. Keep children and adults away from hot surfaces to avoid burns or clothing ignition. Fireplace will remain hot for a time after shutdown. Allow surfaces to cool before touching.

9. Turn the IBV gas logs off and allow to cool before servicing. Always shut off any electricity and gas to the IBV while working on it. Only a qualified service person should install, service or repair this fireplace. Have fireplace inspected annually by a qualified service person.

10. It is imperative that the unit's control areas, burners and circulation air passages be kept clean. More frequent cleaning may be needed due to excessive lint and dust from carpeting, bedding material, pet hair, etc. Turn off gas valve and pilot light before cleaning fireplace.

11. Venting system should be inspected annually by a qualified service person. If needed have venting system cleaned or repaired.

12. Keep all combustible material, gasoline and other flammable liquids at a safe distance from the fireplace. Do not use the fireplace where these items are used or stored. Decorations, clothing and other such combustible items should not be placed on the fireplace.

13. Do not use the IBV to cook food or burn paper or other objects.

14. Do not use any solid fuels - wood, coal, paper, cardboard, etc. - in this fireplace. Use only the gas type listed on the fireplace's gas log label.

15. Do not in any way obstruct the flow of combustion and ventilation air. Provide adequate clearances around air openings into the combustion chamber as well as adequate accessibility clearances for servicing and proper operation.

16. If the fireplace is installed directly on carpeting, vinyl tile or any combustible material other than wood flooring or wood sub-flooring, the appliance shall be installed on a metal sheet, cementitious board or wood panel extending the full width and depth of the unit, including hearth extensions.

WARNING:

This fireplace has not been tested for use with glass doors. To reduce the risk of fire or injury, do not install glass doors.

Some jurisdictions require the use of glass doors. If glass doors are used, operate fireplace with doors in the fully open position.

Safety Information

17. Wherever insulation is used, the fireplace must not be placed directly against it. Keep all insulation and vapor barriers a minimum of three inches (3") away from all IBV and B-Vent chimney components.

18. Insulation or vapor barriers, if used, must first be covered with gypsum board, plywood, particle board or other sheathing material to assure that insulation and vapor barriers remain in place. Do not pack or fill required air spaces with insulation or other material. No material is allowed in these spaces.

19. Never install an IBV component, chimney component or accessory that has visible or suspected physical damage as a result of handling or transportation. These items should be inspected by a qualified representative to ensure safe condition. When in doubt, consult your local supplier.

20. Do not alter or modify the Lennox manufactured B-Vent metal flue or flue components under any circumstances. Modification or alteration of the chimney components may void manufacturer's warranty, listings and approvals.

21. Do not use a fireplace blower insert, heat exchanger or any other product not specified by the manufacturer herein for use with this fireplace.

22. Do not use the IBV appliance if any part has been under water. Immediately call a qualified service technician to inspect the appliance and to replace any part of the control system and any gas control which has been under water.

23. The IBV is not intended to heat an entire home or to be used as a heat source.

24. Negative pressures may result in poor flame appearance, sooting, damage to property and possible severe personal injury. To ensure that an adequate supply of combustion air is accessible consult with a local HVAC engineer.

25. **Children and adults should be alerted to the hazards of high surface temperature and should stay away from this appliance to avoid burns or clothing ignition.**

26. **Young children should be carefully supervised when they are in the same room as the appliance.**

27. **Clothing or flammable material should not be placed on or near the appliance.**

28. Installation and repair should be done by a qualified service person. The appliance should be inspected at least annually by a professional service person. More frequent cleaning may be required due to excessive lint from carpeting, bedding material, etc. It is imperative that control compartments, burners and circulating air passageways of the appliance be kept clean.

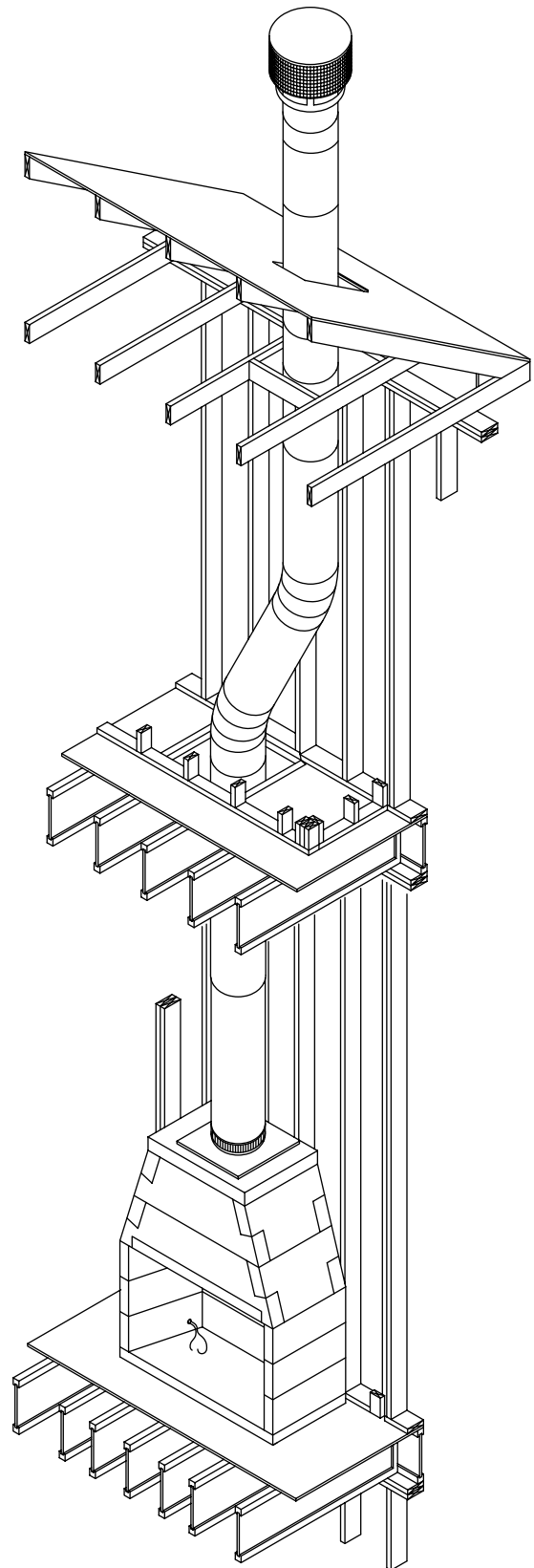

Assembled Firebox & Smoke Dome Dimensions

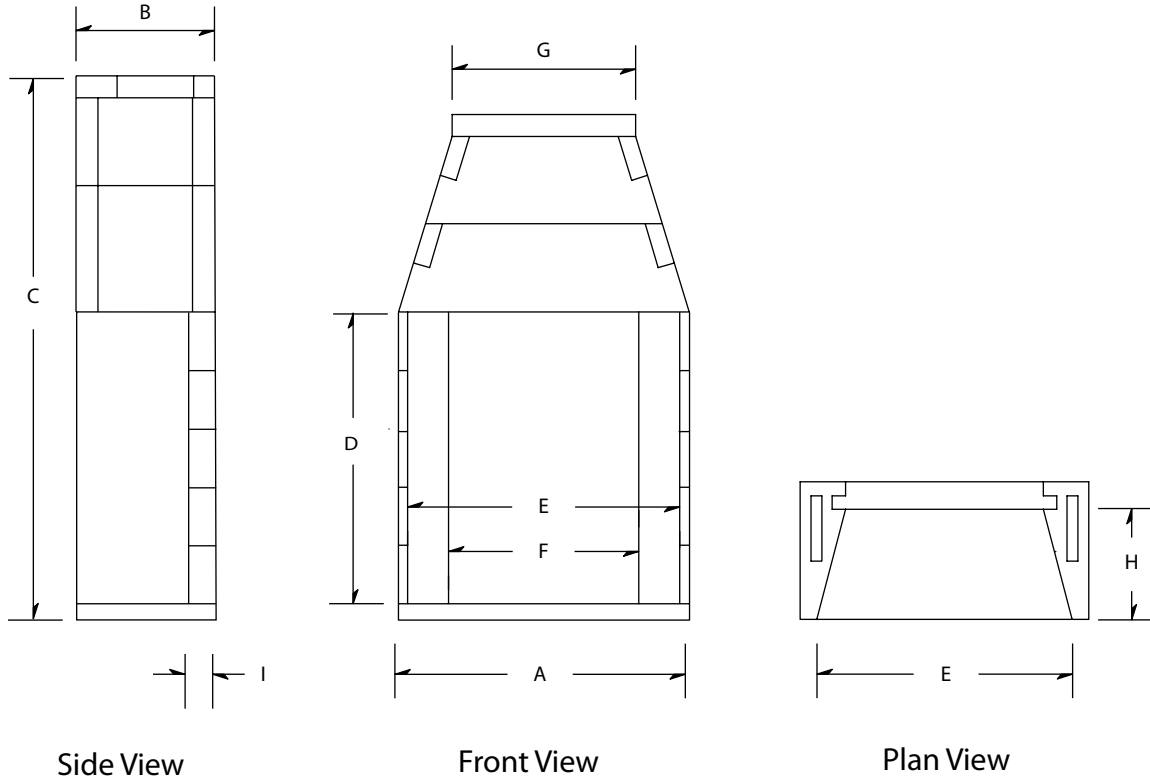

Model	A	B	C	D	E	F	G	H	I	Minimum Framing	Weight
36"	43"	25¼"	71 1/4"	31 1/2"	36 1/8"	27 1/4"	21½"	20¼"	5"	43" W x 71 1/4" H x 26 3/4" D	1500 lbs.
46"	53"	25¼"	71 1/4"	31 1/2"	47 1/8"	37 1/4"	32"	20¼"	5"	53" W x 71 1/4" H x 26 3/4" D	1700 lbs.
*To achieve height dimension "D" in table above, a 100' (8.3') minimum flue height with 10" I.D. B-Vent is required											
36"	43"	25¼"	81 3/4"	*42"	36 1/8"	27 1/4"	21½"	20¼"	5"	43" W x 81 3/4" H x 26 3/4" D	1650 lbs.
46"	53"	25¼"	81 3/4"	*42"	47 1/8"	37 1/4"	32"	20¼"	5"	53" W x 81 3/4" H x 26 3/4" D	1850 lbs.
*To achieve height dimension "D" in table above, a 9' minimum flue height with 10" I.D. B-Vent is required											
36"	43"	25¼"	92 1/4"	*52 1/2"	36 1/8"	27 1/4"	21½"	20¼"	5"	43" W x 92 1/4" H x 26 3/4" D	1800 lbs.
46"	53"	25¼"	92 1/4"	*52 1/2"	47 1/8"	37 1/4"	32"	20¼"	5"	53" W x 92 1/4" H x 26 3/4" D	2000 lbs.
*To achieve height dimension "D" in table above, a 12' minimum flue height with 10" I.D. B-Vent is required											

Earthcore Industries, LLC. reserves the right to make changes at any time, without notice, in design, materials and specifications and also to discontinue styles and product. Phone 800-642-2920 or visit: www.earthcore.co

Component List & Dimensions

Part No.:	Fireplace Size:	Quantity:
21	36"W	1
23	46"W	1

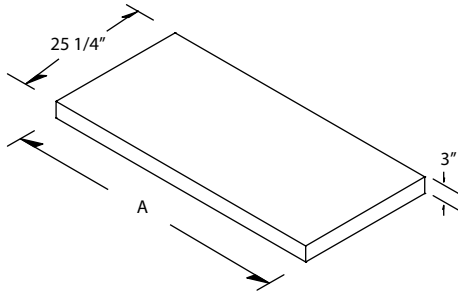

BASE PLATE

Model	A
36"	43"
46"	53"

Part No.:	Fireplace Size:	Quantity:
34	36"W	4
34	46"W	4

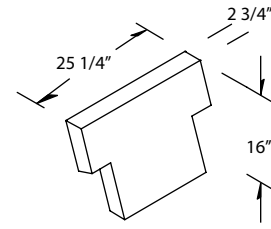

TOP - SLOPING

Part No.:	Fireplace Size:	Quantity:
20	36"W	6
20	46"W	6

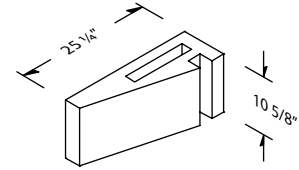

SIDE WALL

Part No.:	Fireplace Size:	Quantity:
12	36"W	2

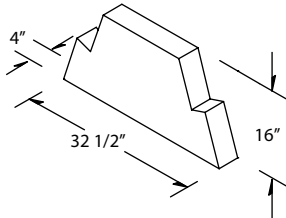

TOP - SMALL

Part No.:	Fireplace Size:	Quantity:
25	36"W	3
31	46"W	3

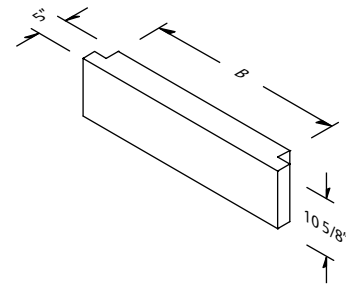

BACK WALLS

Model	B
36"	26 3/4"
46"	37 1/2"

25, 31 - stacked two (3) high

Part No.:	Fireplace Size:	Quantity:
11	36"W	2
11	46"W	2

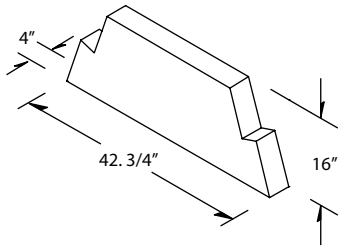

TOP - MEDIUM

Part No.:	Fireplace Size:	Quantity:
13	46"W	2

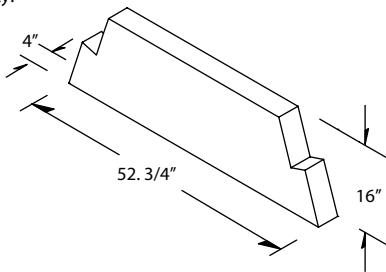

TOP - BIG

Part No.:	Fireplace Size:	Quantity:
36	36"W	1

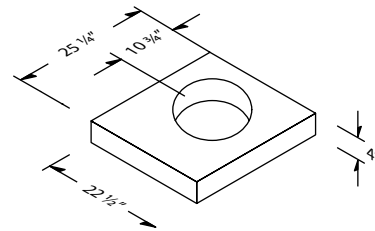

TOP PLATE SMALL

Part No.:	Fireplace Size:	Quantity:
37	46"W	1

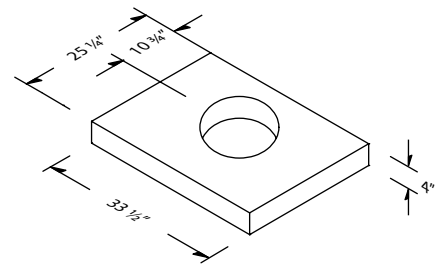

TOP PLATE LARGE

Required Component List

In addition to the standard IBV modular masonry firebox and smoke dome assembly components the IBV requires particular components necessary to complete the installation and meet the ANSI Z-21.50 listing. The two boxes of special IBV components include the following:

IBV Box 1 of 2:

1. One (1) B-Vent Installation, Operation, Maintenance and Owner's Manual
2. One (1) metal canopy/wiring raceway with 4 mounting screws with high temperature limit switch and damper macro switch/lever assembly pre-mounted. Warning stickers attached.
3. Two (2) high temperature wires, twelve feet long (12')

IBV Box 2 of 2:

1. One (1) 10" anchor plate / down draft diverter / B-Vent starter collar/in-line damper combination unit with 4 mounting screws
3. One (1) C-Clamp warning label
2. One (1) ceramic fiber blanket - 24" x 24" x 1/2 inch thick

Required Clearance to Combustibles

Important: "Combustibles" are defined as "normal construction materials" and considered to be: wood framing materials, particle board, mill board, plywood paneling, plywood subflooring and wood flooring.

The IBV is listed for installation with "clearance to combustibles" (shown below) as follows:

- A:** Zero inch (0") clearance to the combustible floor;
- B:** Zero inch (0") clearance at the Isokern firebox and smoke dome sides and front ;
- C:** One and one half inches (1-1/2") clearance at the Isokern firebox and smoke dome back wall ;
- D:** One inch (1") minimum air space to combustibles at all B-Vent double wall chimney components' outer layer.
(Contact pipe manufacturer for specific clearance information)

CAUTION: Maintain three inches (3") clearance to insulation and vapor barriers from all firebox, smoke dome and B-Vent flue components' outer layer.

Notes:

1. The IBV is designed, tested and approved for installation directly on a combustible floor system per the installation specifications given in this manual.
2. All IBV installations will result in the minimum finished fire brick floor of the firebox being at least four and one half inches (4-1/2") above the combustible floor system. For flush hearth installations, consult your local representative.
3. The combustible floor in front of the fireplace must be covered with a noncombustible hearth extension material set tight against the fireplace front and extending at least twenty inches (20") out from the finished front of the fireplace and at least twelve inches (12") beyond the finished sides of the fireplace opening (See page 28).

WARNING: Combustible objects placed in front of the fireplace must be kept to a minimum of forty eight inches (48") clearance to the fireplace opening.

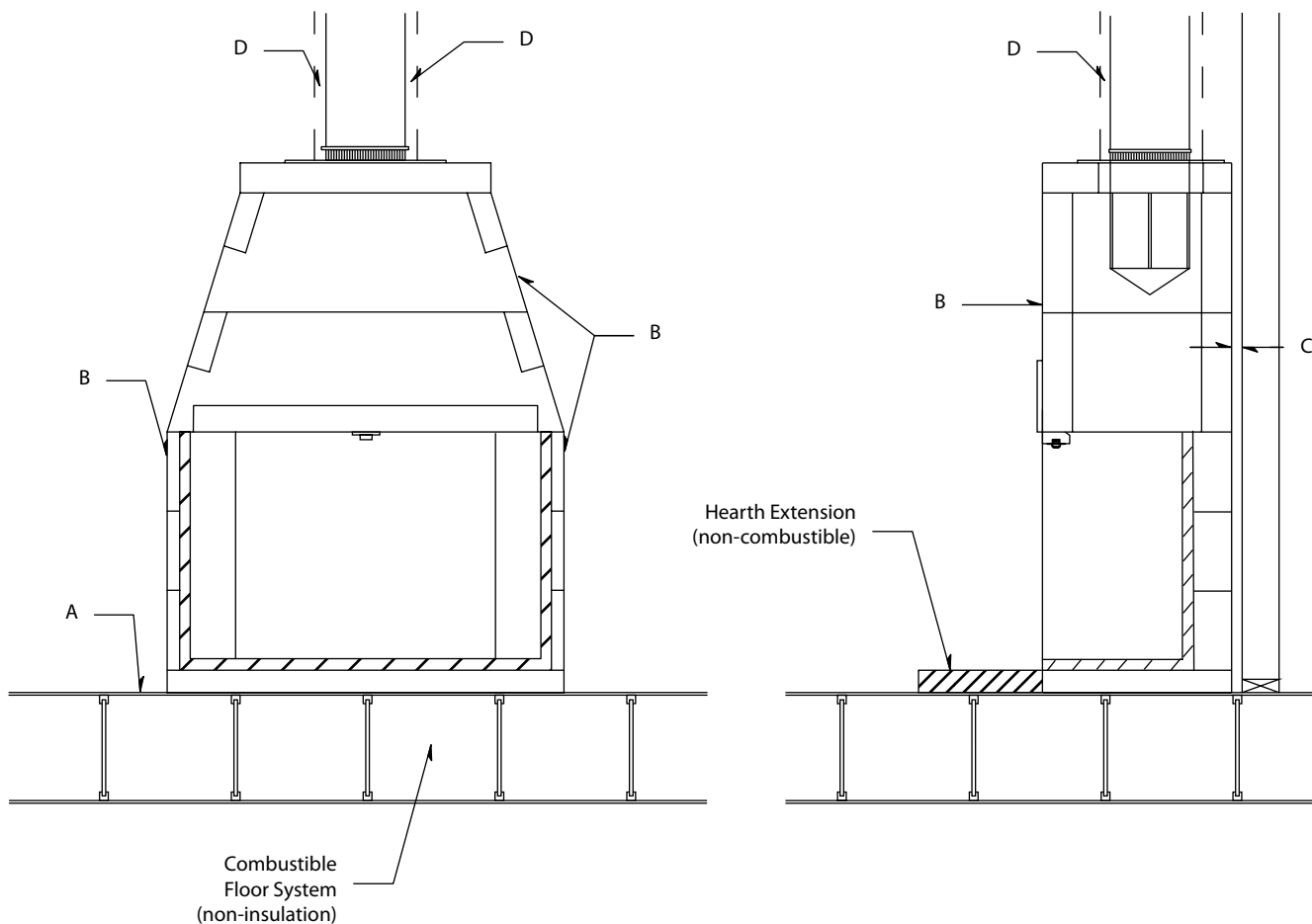

Combustible Floor System Loading

Important:

Floor framing for IBV installation will need to be designed and built to accept substantial dead loads spread over a relative small floor area. (Figure 1)

The following weights and sizes can be used to calculate loading. It is the contractor's responsibility to provide adequate floor system load capacity.

IBV Weights and Load Calculations:

Total dead load amounts include (but are not necessarily limited to) the following items and their corresponding weight estimates as listed below:

1. Isokern unit model weights:
 - a. IBV-46: 1400 lb
 - b. IBV-36: 1200 lb
2. Approximate weight of log set: 100 lb.
3. Fire brick and mortar: 350 lb.
4. Facing material: per general contractor
5. B-Vent metal flue: per manufacturer

The floor area for each model is as follows:

IBV-46 @ 53" x 25.25" = 9.30 sq. ft.

IBV-36 @ 43" x 25.25" = 7.54 sq. ft.

Notes:

1. Earthcore is not responsible for structural floor support details for this fireplace system. Unless otherwise noted all floor framing drawings in this manual are merely illustrations to indicate the presence of an underlying floor system.

2. Consult your local structural engineer for proper floor system design, sizing and specifications.

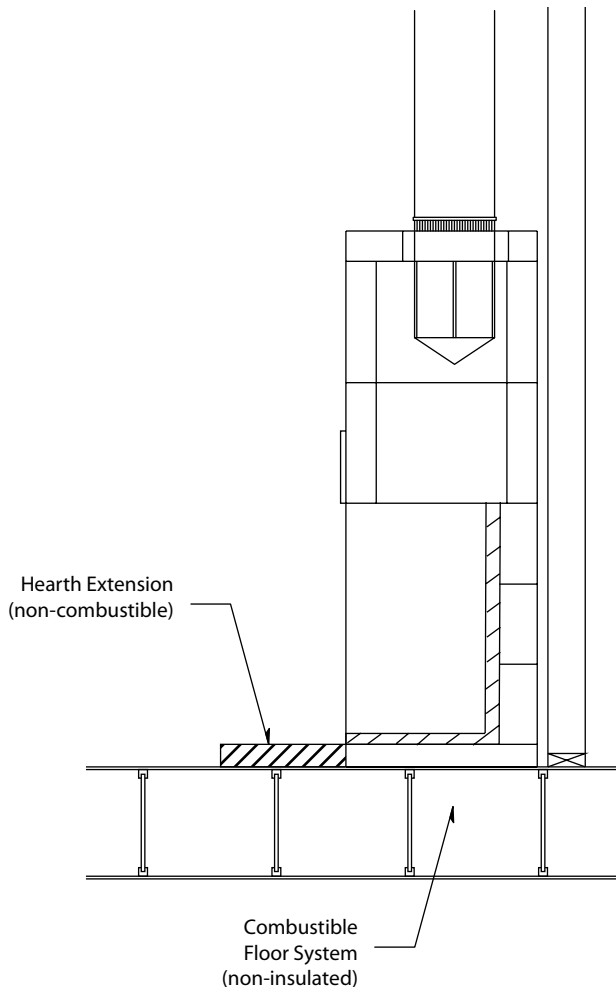

Figure 1

IBV Rough Framing Dimensions

Rough Framing Dimensions			
Model	A	B	C
IBV 36	43"	72",83",93"	26 3/4"
IBV 46	53"	72",83",93"	26 3/4"

Notes:

1. "Raised hearth" requires additional rough opening height at "B" equal to the height of the raised hearth detail.
2. Rough framing dimension for depth "C" allows for one and one-half inch (1-1/2") clearance at the back of the IBV.
3. Keep all insulation and vapor barriers three inches (3") away from all IBV surfaces.
4. Opening height of 83" requires minimum 9' flue; 93" height requires minimum 12' flue.

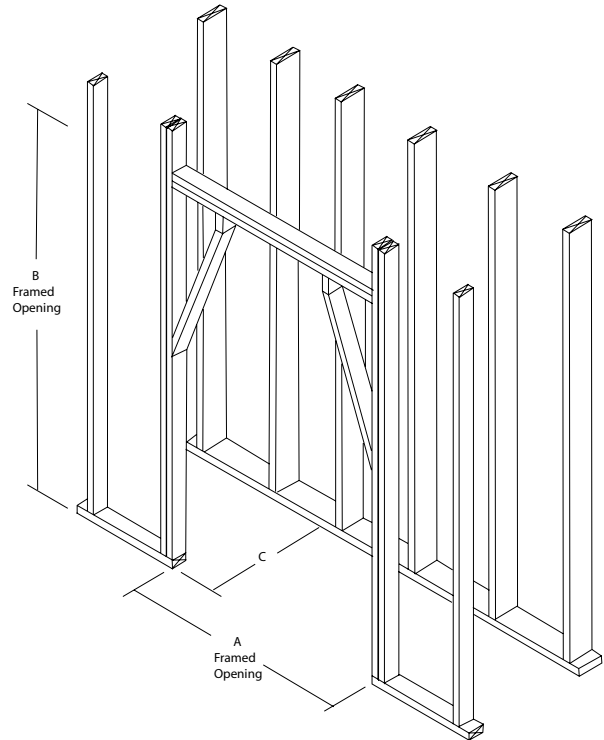

IBV Corner Location Layout

The following chart of plan dimensions is intended to aid in the positioning of an IBV in a corner condition.

Model	A	B	C	D
IBV 36	43"	49"	32"	70"
IBV 46	53"	59"	39"	77"

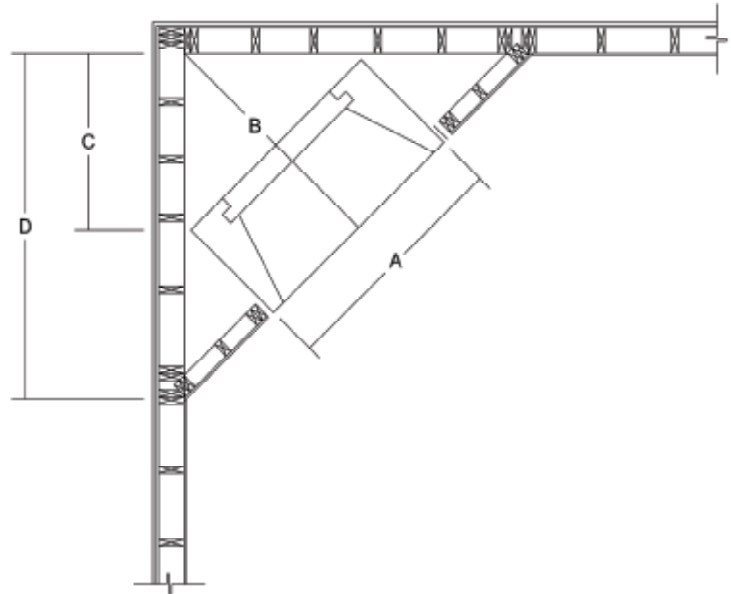

IBV Assembly Instructions

General Assembly Instructions:

Earthcore Mortar (a thin-set type masonry adhesive) is used to glue all IBV masonry components together during field assembly of the unit. The mortar is supplied dry, in either 15 pound or 50 pound pails.

Earthcore Mortar is mixed with clean water to a smooth, workable texture (without lumps or dry pockets) of a “toothpaste” consistency. This mixture is suitable for application onto IBV components by using a masonry grout bag such as the one supplied with the unit.

Attention should be paid that the mortar mixture is not too thin or runny, as this will not allow the mortar to reach its maximum bonding strength.

Earthcore Mortar is squeezed from a grout bag onto the contact surfaces of the IBV components as they are fitted together. (Figure 2)

It is important that a one-half inch (1/2”) bead of mortar on all the components’ contact surfaces is applied at about one-half inch (1/2”) in from all edges of the contact surface of the component.

When setting a component onto the mortared contact surface of the preceding component, some mortar should squeeze out along the face of the entire joint as a sign of complete and proper sealing of the joint.

On broader contact surfaces it is advisable to apply several additional one-half inch (1/2”) beads of the Earthcore Mortar to the area to assure proper sealing of the joint.

Properly mortared firebox and smoke dome requires approximately 25 pounds (dry measure) of Earthcore Mortar.

Broken Components: Components broken into two or three pieces can be glued together along the break line with Earthcore Mortar as the component is set into place. Components broken into multiple small pieces should be discarded and replaced.

Leveling and Aligning Components: Be sure to assemble all IBV components level and flush with adjoining components.

Leveling and alignment adjustments are made by the use of small plastic shims (supplied with the unit). The shims can be inserted under a component to level and align it with adjacent IBV components (Figure 3). Be sure to add mortar to all gaps resulting from shim insertion.

Notes:

1. Do not mix Earthcore Mortar with spirits or anti-freeze agents.
2. The maximum recommended mortar joint thickness at IBV components is one quarter inch (1/4”).
3. Earthcore Mortar can be troweled over the face of a joint where it has squeezed out while setting components. It is not intended that the exposed faces of IBV components be completely covered with the mortar.

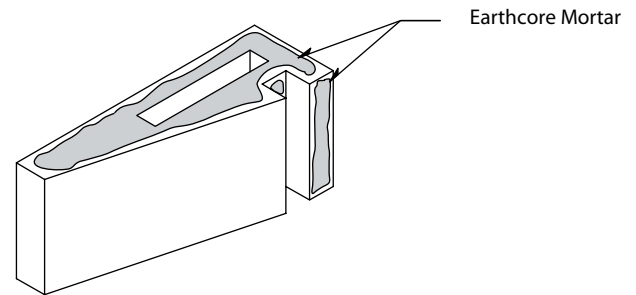

Figure 2

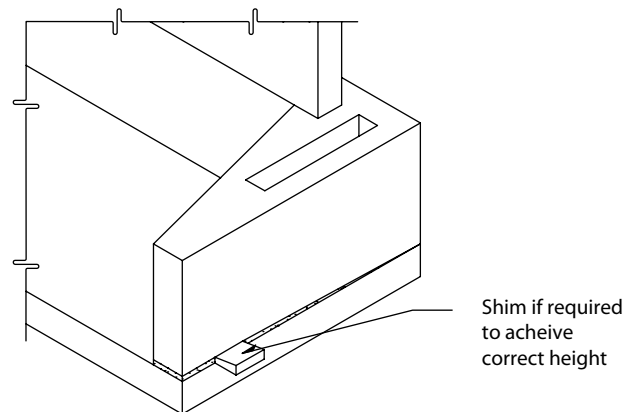

Figure 3

IBV Assembly Instructions (cont.)

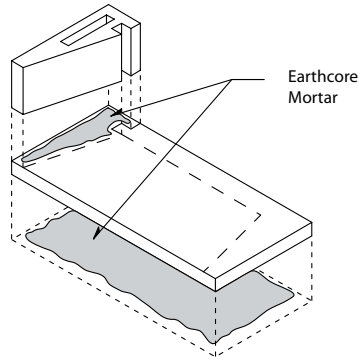

Figure 4

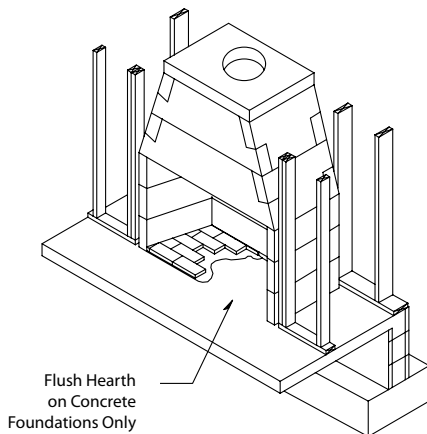

Figure 5

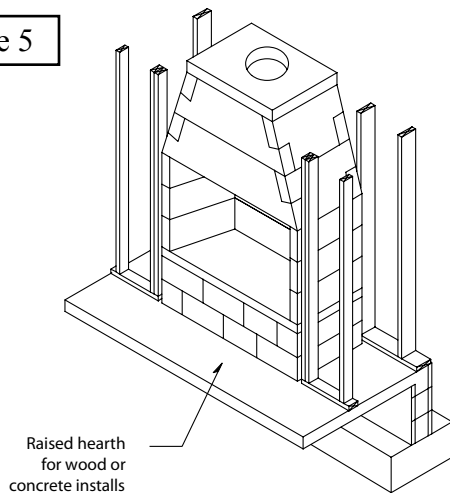

Figure 6

Assembly Steps for IBV firebox and smoke dome:

Step 1: The IBV base plate can be set directly on a combustible floor system. Set the base plate level in a bed of Earthcore Mortar so that the base plate is in full contact with the underlying floor system (Figure 4). Do not set the IBV base plate in span.

Raised and Flush Hearth Application:

For a "flush hearth" the IBV must be built upon a concrete (noncombustible) support slab that has no wood underpinnings. (Figure 5) For a "flush hearth" application the IBV three inch (3") thick base plate is omitted from the assembly. The firebrick will then be mortared on the concrete slab and the noncombustible hearth material will butt tight up against it.

For a "raised hearth" (floor of the fireplace elevated above the room's floor) the IBV base plate can be set on a structurally sound built up platform that is built to the desired finished raised hearth height.

When calculating raised hearth height be sure to allow for the three inch (3") thick base plate plus the one and one-half inch (1-1/2") thick fire brick floor in addition to the height of the field constructed raised platform. (Figure 6)

WARNING:

"Flush hearth" installations are possible only where the IBV support is a concrete slab without any wood underpinning as the base plate is omitted. Never place an IBV on a combustible floor without the base plate.

IBV Assembly Instructions (cont.)

Step 2: Set the first course of the firebox back wall and side walls into place on the base plate. (Figure 7)

It may be convenient to temporarily dry set the first course of side wall and back wall into place on the IBV base plate and then to trace their position on the base plate with a pencil.

Remove the dry set pieces and apply Earthcore Mortar to the areas traced on the base plate where the side walls and back wall are to sit. By doing this, the first layer of wall components can be set directly into mortar already applied to the proper areas on the base plate.

Be sure to put Earthcore Mortar on the contact surfaces of the vertical joints where the side wall and back wall components connect. (Figure 8)

Step 3: It is required that the two supplied high temperature wires be routed from the inside of the IBV as follows:

Once the lowest, left hand side wall firebox component is set in place (left, when facing the fireplace) drill a 1/4" - 3/8" dia. hole in the inner face of this side wall located four to six inches (4" - 6") out from the back wall of the IBV and at three to four inches (3" - 4") above the IBV base plate. (Figure 9)

This drill hole must intersect the hollow core of the IBV firebox side wall.

Feed the two lengths of high temperature wire from the inside of the IBV firebox through the drill hole and into hollow space of the firebox side wall. Bring the two lengths of wire up and out through the top of the side wall component (Figure 9).

Step 4: Continue assembly of the second and third courses of the firebox side wall and back wall. Apply Earthcore Mortar to the top of each layer of wall components, then set the next course above into place.

Be sure to apply mortar to all vertical joints of the side wall to back wall connection when setting each component to its mate. (Figure 9)

Look for some Earthcore Mortar to squeeze out along the joints of all component contact surfaces as a sign that the joint is thoroughly sealed with mortar.

Continue to feed the two high temperature wires up through the hollow core of the left hand sidewall stack.

Be sure to leave approximately four feet (4') of each of the two high temperature wires out of the top of the left hand side wall of the firebox for later connection to the high temperature limit switch and also four feet (4') of each wire loose inside the firebox for later connection to the pilot assembly. (See wiring diagram, page 29.)

Note:

1. High Temperature Wire Specifications: Supplied by others.

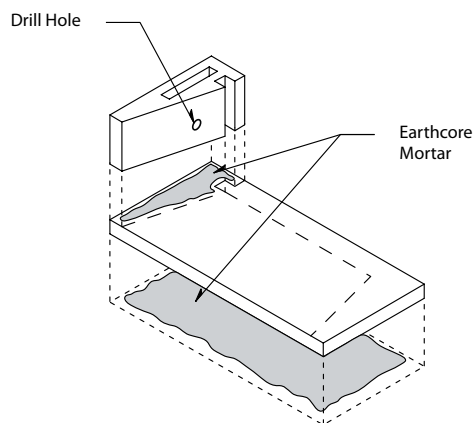

Figure 7

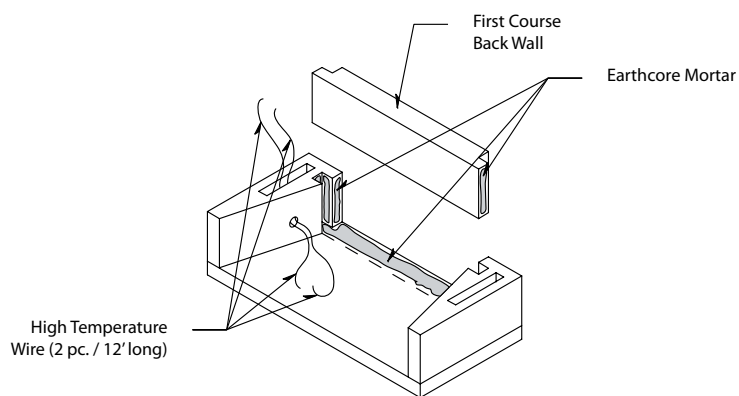

Figure 8

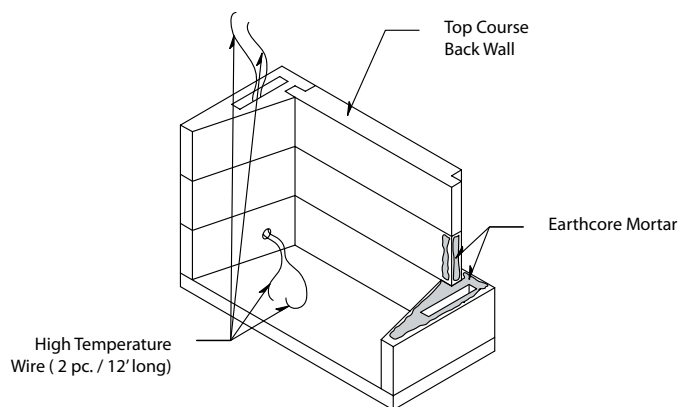

Figure 9

IBV Assembly Instructions (cont.)

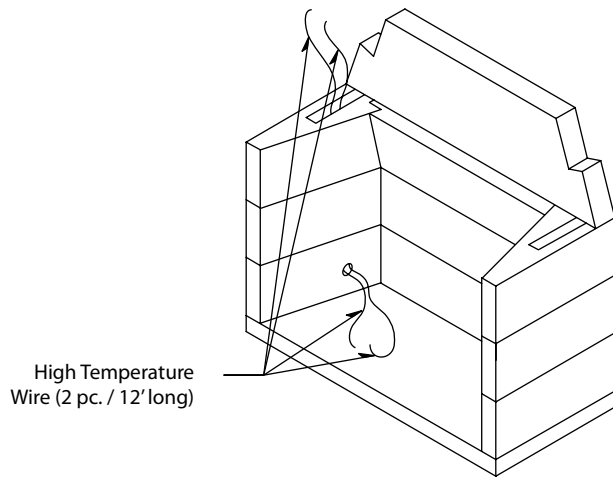

Figure 10

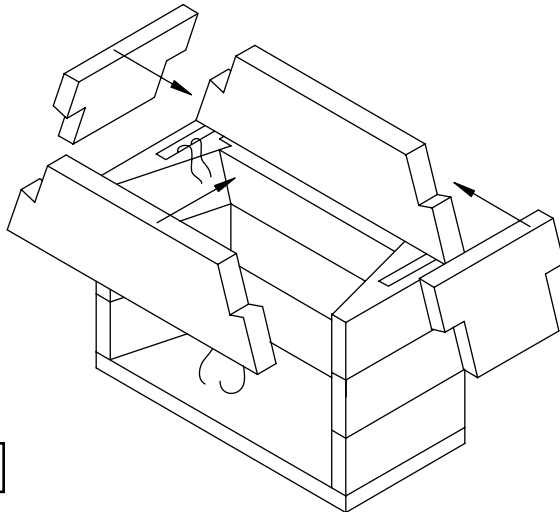

Figure 11

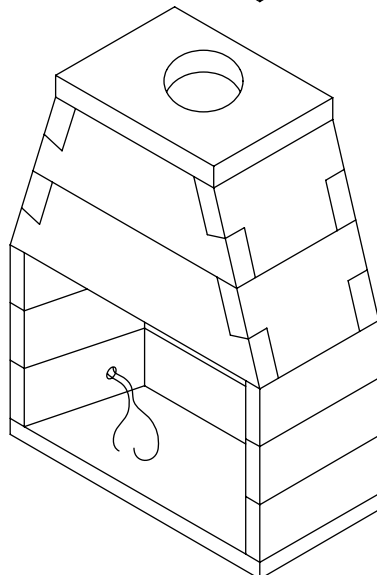

Figure 12

Step 5: Once all the firebox wall components are set check the top surface of the firebox for level.

Step 6: Begin the smoke dome assembly by setting the rear bottom smoke dome component on top of the firebox back wall assembly in a bed of Earthcore Mortar. The smoke dome component should sit flush with the back side of the firebox assembly. (Figure 10)

Step 7: Set the front bottom smoke dome component across the firebox opening so that the smoke dome piece spans the firebox opening and is flush with the front of the firebox.

Step 8: Position the smoke dome's sloping sidewalls at each end of the bottom smoke dome components (Figure 11).

The sloping sidewalls fit in between the front and rear smoke dome components and also fit into the haunches at the ends of the front and rear smoke dome components.

The smoke dome sloping sidewalls have a beveled bottom edge so that they will sit tight onto the flat top of the firebox side walls.

Step 9: Set the upper course of front and rear smoke dome components directly on top of and aligned with the bottom front and bottom rear smoke dome components that are already in place.

Set the two upper smoke dome sloping sidewalls into position, one at each end of the upper front and rear smoke dome components. (Figure 12)

Step 10: Ensure that all component contact surfaces have been properly sealed with Earthcore Mortar.

Check smoke dome front and back walls to see that they are plumb, level and in alignment with adjoining components.

Check alignment of the smoke dome sloping sidewall components to see that they are flush with one another and create smooth and uniform smoke dome Sidewalls for the total height of the smoke dome.

Step 11: Set the smoke dome top plate into position on top of the smoke dome wall assembly, with the flue hole closer to the rear. (Figure 12)

Be sure to set the smoke dome top plate flush with the front, back and sides of the smoke dome assembly.

IBV Assembly Instructions (cont.)

Access Modification:

1. Gas Line Feed: These provisions for installation of a gas pipe is only for connection to the included ISOFLAMES decorative gas log set. The ISOFLAMES decorative gas log set incorporates an automatic shutoff device and complies with the Standard for Decorative Gas Appliances for Installation in Vented Fireplaces, ANSI Z21.60. The ISOFLAMES decorative gas log set should be installed in accordance with the ISOFLAMES Gas Log installation manual (pages 30 through 37) and per the National Fuel Gas Code, ANSI Z223.1.

The gas line for the ISOFLAMES gas log set used in the IBV firebox should be routed through the left side wall of the firebox (left, when facing the unit) by drilling an appropriately sized hole using a masonry drill bit (Figure 13).

CAUTION: Avoid the high temperature wire when drilling gas line hole.

Notes:

1. Gas Line and Electric Line must be fed through separate access holes.

2. Combustion Air Inlet: Combustion air inlet kits though not required for IBV may help improve fireplace operation. (Figure 14 & 15). Check local codes for combustion air requirements.

The access door is fitted into the finished fire brick lining at the interior of the IBV firebox. The twelve inch (12") long sleeve can be introduced into the firebox right hand side wall by core drilling an appropriately sized hole through the right-hand side wall keeping the hole two inches (2") above the rough floor of the firebox. (Figure 13)

The hole size should allow for a one quarter inch (1/4") mortar joint around the air access sleeve. The sleeve passes through the firebox wall and must be connected to metal pipe - either flexible or rigid - that leads to the source for outside combustion air, maximum length sixty feet (60'). Maintain clearance of at least two inch (2") to air kit sleeve as it exits the outer surface of the IBV side wall.

All access holes must be grouted with mortar - after line or conduit feed - to seal any gaps or cracks around line feed conduits (Figure 15).

WARNING: Do not use combustible duct material. Avoid installing a combustion air inlet where the opening could be blocked by snow, bushes or other obstacles. Air inlet must terminate a minimum of three feet below the chimney cap level. Air inlet ducts shall not terminate in attic spaces.

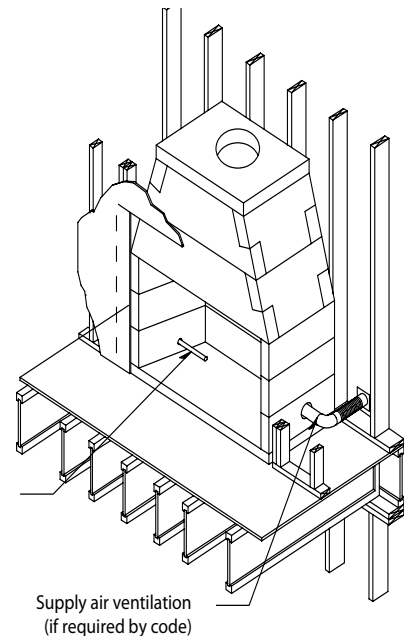
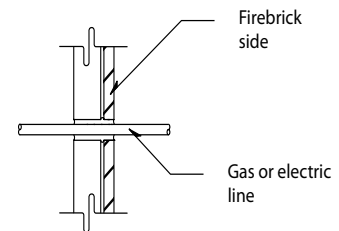

Figure 13



NOTE: Fill any gaps around line with Earthcore Mortar

Figure 14

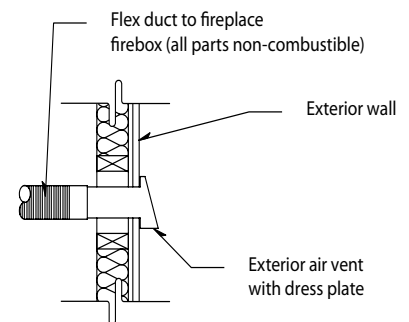

Figure 15

NOTE: Gas lines and combustion air ventilation placement can be reversed. This page used for illustration of systems only.

IBV Assembly Instructions (cont.)

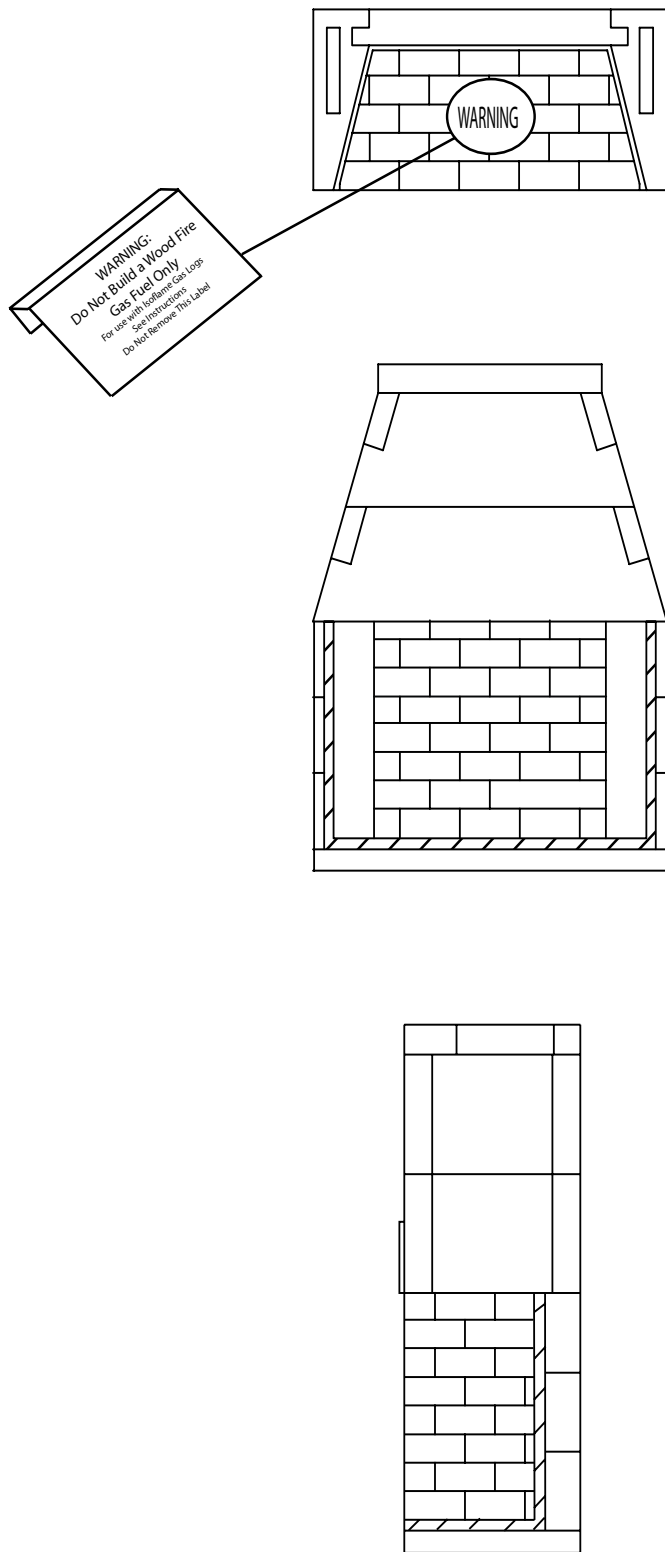

Figure 16

Fire Brick Installation:

The manufacturer requires that the IBV firebox be lined with a minimum one and one-eighth (1-1/8") thick rated fire brick. The pattern for the fire brick lining is an owner option. Standard N or S -Type brick mortar is a suitable fire brick mortar for the IBV. Add a small portion of Earthcore mortar to make it a sticky consistency with a 1/4" notch trowel bed joint. Because of different climates, the use of good masonry practices for your area should also be considered.

All required through-wall accesses (gas and electrical line feeds and combustion air supply access holes) should be drilled before the required fire brick lining is installed.

It takes a total of about five gallons of mortar mix (dry measure) to fire brick line an IBV.

Face joints of one quarter inch (1/4") to three-eighths inch (3/8") give a good appearance to the finished brickwork. However, larger face joint dimensions are also acceptable.

Step 1. Wet mop the inside of the IBV with a damp sponge to remove dust and loose particles from the interior before installing fire brick.

Note: It is a good practice to dip each brick in water before installing.

Step 2. Start the fire brick at the front edge of the floor of the Isokern firebox, proceeding inward toward the back.

Step 3: Apply C-clamp warning label to center floor brick prior to mortar, ensuring verbiage is legible from front of firebox. (Figure 16)

Step 4. Next, apply fire brick to the back wall of the unit starting at the bottom of the back wall and working upward to the top of the back wall.

Step 5. Finally, set the side wall fire brick by starting at the front edge of the unit's side wall and working inward toward the back wall fire brick.

Important: Be sure to bring the two high temperature wires through the lower left hand side wall finished fire brick. The two high temperature wires need to be accessible for later connection to the high temperature limit switch wires.

IBV Assembly Instructions (cont.)

Metal Canopy Installation:

The metal canopy, as supplied, is forty five inches (45") long and fits the IBV models 36 & 46. Field cut the metal canopy equally at the perforated lines as required for the 36" unit. This will ensure the limit switch and micro-switch are located in the proper position on the lintel.

Connect the two (2) leads from the high temperature wires to the thermocouple junction block (see diagram, page 29).

Measure and locate the centerline of the fireplace opening. Align notch at the front of the lintel to the centerline of the fireplace. Install lintel using 1 1/2" masonry screws.

Notes: The limit switch and microswitch are already supplied and mounted in the IBV metal canopy component. Connect the two high temperature wires (coming out the top of the IBV left hand firebox side wall) to the two high temperature wires that are attached to the limit switch with ceramic wire nuts.

The small tab near damper lever should be bent upward to stand vertical. This protects wires passing through the harness.

WARNING: Do not bypass the high temperature limit switch. Install downdraft diverter at the top plate. (Figure 20)

Orient assembly such that the wire cable is toward the front of the fireplace opening.

Loosen screws on the cable clamp and loop between the two washers at the end of the handle assembly.

Note: Wire clamp should be approximately 4" from the washers. Tighten lock nuts on the handle if necessary.

Pull cable to close the damper and adjust the length of wire cable by swinging the handle between open and close positions. When in the open position, the damper should be rotated a full 90 degrees from the closed position.

Retighten screws on the cable clamp and remove excess cable.

The metal canopy fits horizontally up toward the bottom of the smoke dome. The adjoining short leg of the metal canopy fits up against the bottom of the smoke dome component. (Figure 19)

The metal canopy has 4 pilot holes for the screw placement.

Attach the metal canopy flush against the front face of the smoke dome with 4 mounting screws driven into the face of the IBV smoke dome.

Any excess wire draped between the metal canopy and the left hand firebox sidewall should be neatly tucked into the hollow core of the left hand sidewall. Excess wire should not be visible below the canopy bottom.

The 2 high temperature wires inside of the IBV firebox will connect to the appropriate contacts found on the gas log assembly during the installation of the gas log set.

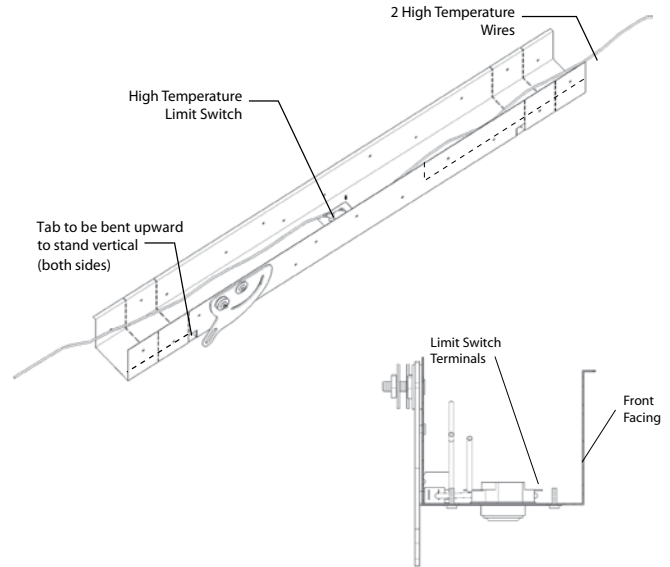

Figure 17

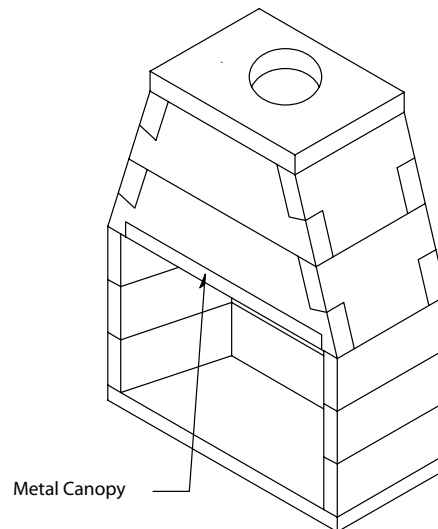

Figure 18

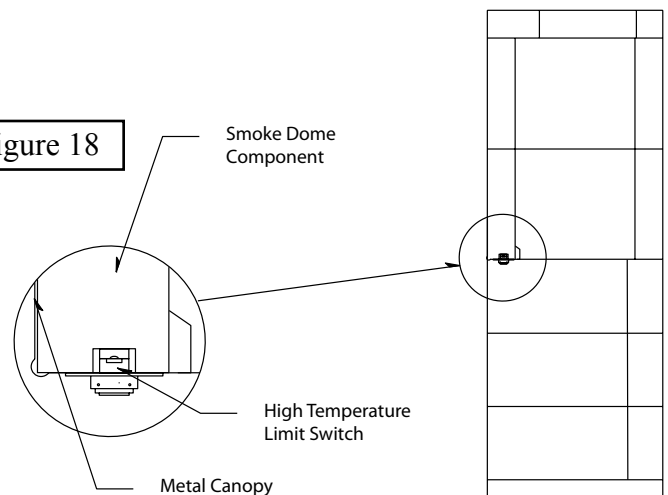

Figure 19

Venting Installation

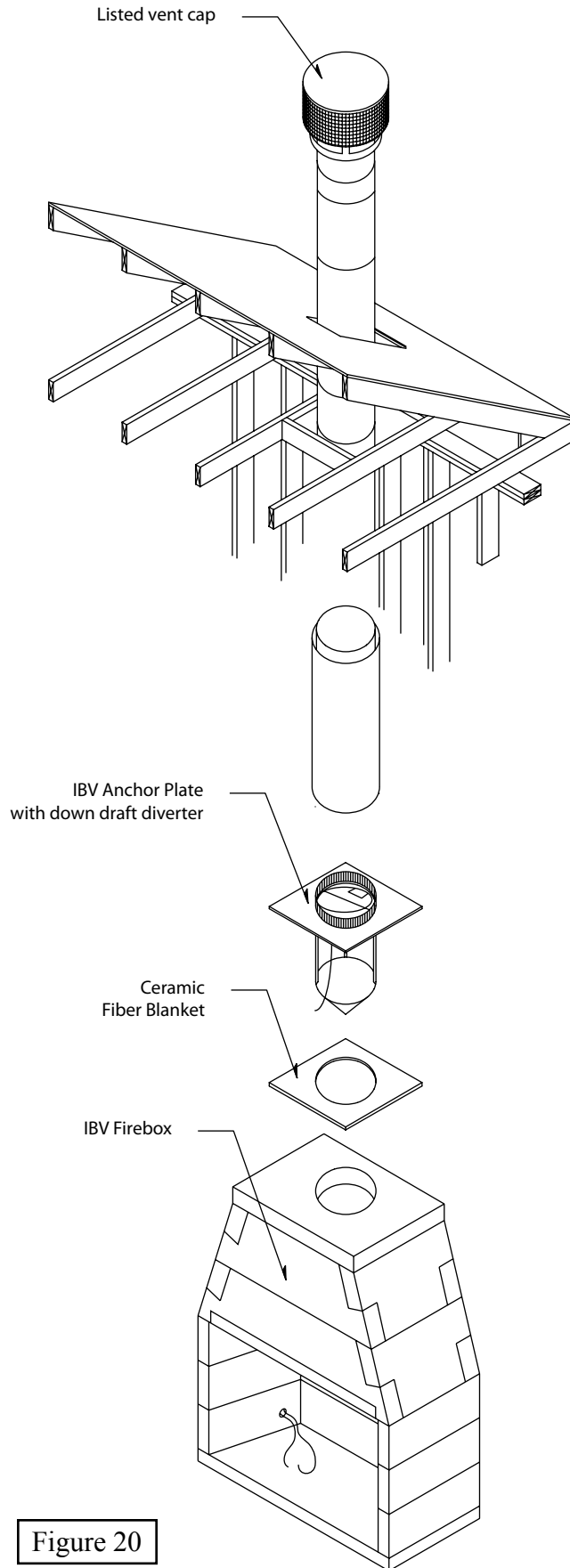

Figure 20

Anchor Plate/ Damper Installation:

Cut a twelve inch (12") diameter hole in the center of the ceramic fiber blanket which is then placed on the top plate, aligned with and centered on the flue hole in the top plate.

The IBV anchor plate assembly is then dropped into the hole in the top plate so that the conical shaped down draft diverter / in-line damper assembly hangs down into the smoke chamber (Figure 20).

When properly installed the wire cable is toward the the front of the fireplace.

The mounting flange connects to the IBV top plate by setting four screws (one and one-quarter inch (1-1/4") galvanized drywall screws) through the flange, through the ceramic fiber blanket and into the IBV top plate.

To install B-Vent piping, slide the first piece of ten inch (10") inside diameter B-Vent pipe over the IBV starter collar and attach with either two screws or other means approved by the vent manufacturer.

Actual installations will vary due to individual job requirements. However, always maintain required clearances to combustibile materials and do not violate any specific B-Vent installation requirements - ANSI Z223.1 / NFPA 54. Check with the B-Vent manufacturer regarding specific clearances.

Be sure that in every case where offsets are used that they are properly supported and that fire stops are used wherever the vent passes through a sub-floor, ceiling joist system or an attic overhang.

The vent pipe must terminate with a listed type vent cap and extend through an approved roof flashing, roof jack or a roof thimble vertically through the roof. Be sure to maintain the listed clearances at all points of the vent system installation.

Venting Installation (cont.)

The IBV, per ANSI-Z21.50 standard, requires double wall, gas only B-Vent metal piping for the purpose of venting the appliance to the outside of the building.

Specifications:

Gas code requirements concerning B-Type vent installations may vary within state, province or local code jurisdictions. Therefore it is recommended that you check with local building codes prior to installing any B-Vent piping for specific requirements or, in the absence of local codes follow Section 7.0 of the current National Fuel Gas Code ANSI Z223.1, NFPA 54.

1. The IBV must be vented vertically out the top of the unit.
 2. All B-Vent flue used with IBV must terminate vertically through the roof.
 3. All B-Vent flue used with IBV may not be terminated into an attic space.
 4. The B-Vent flue used with IBV must only be used for the IBV and not shared with other venting systems.
 5. Maintain a minimum one inch (1") air space at all double wall B-Vent metal pipe components.
 6. Maintain a minimum two inch (2") air space at all single wall B-Vent metal pipe components.
- Note:** Check with pipe manufacturer for specific clearance requirements.
7. Maintain a minimum three inch (3") air space to all insulation and vapor barriers.
 8. Minimum required chimney height is one hundred inches (100"). (Figure 21)
 9. Maximum chimney offset angle is forty-five degrees off of vertical. (Figure 21)
 11. Only one offset per chimney system is allowed.

CAUTION: Do not modify or alter metal flue or metal flue components as this could result in an unsafe and potentially dangerous installation that may cause a serious injury. Consult B-Vent manufacturer.

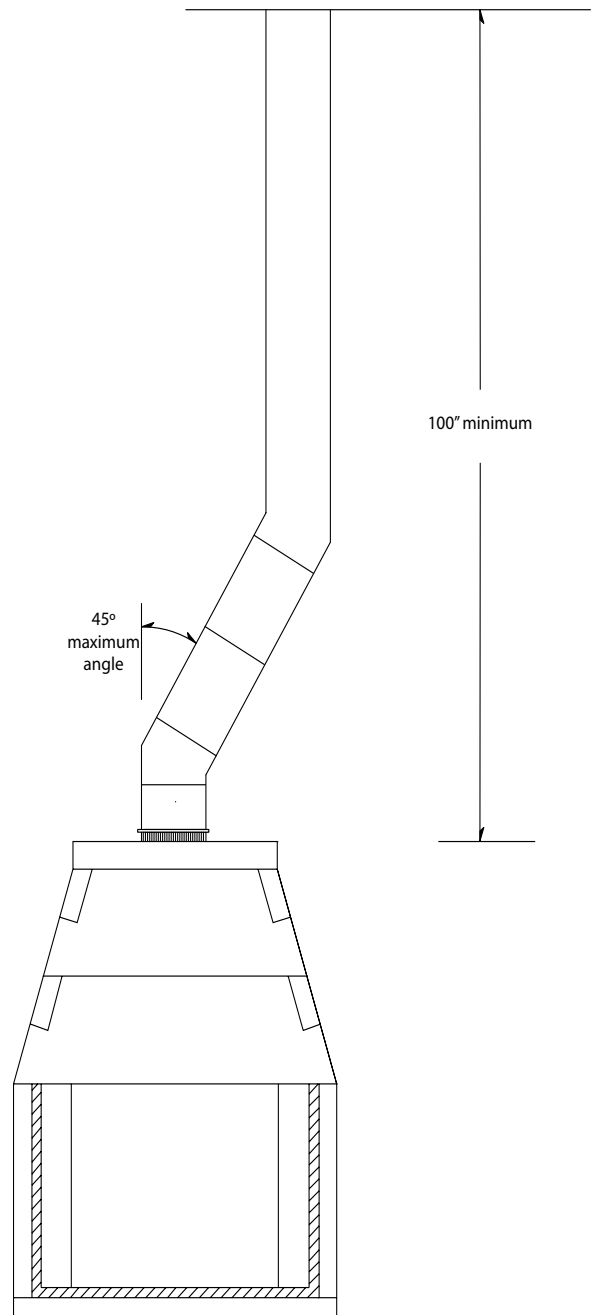

Figure 21

Venting Installation (cont.)

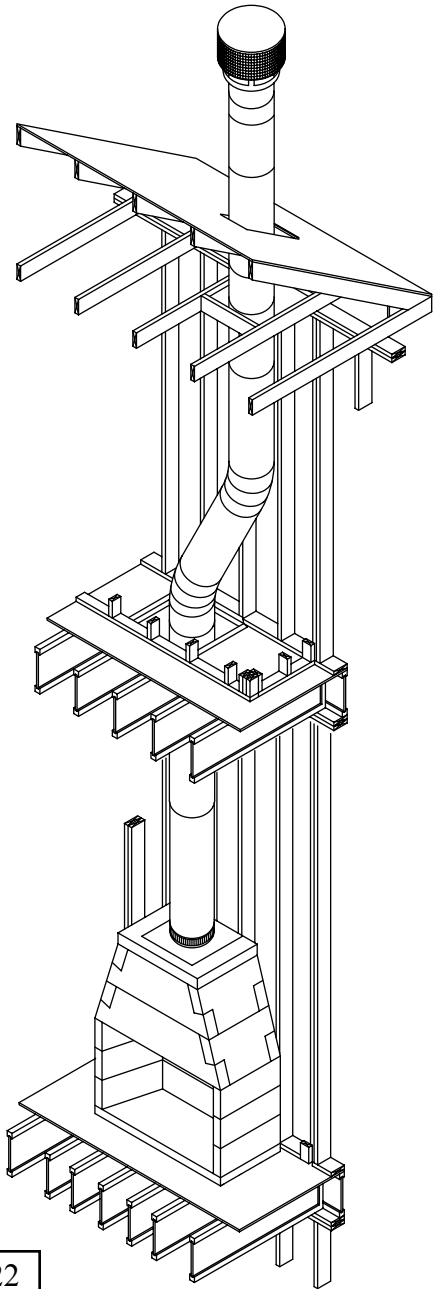

Figure 22

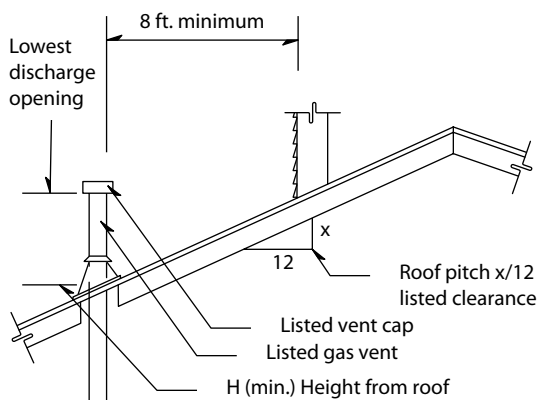

Figure 23

Mechanical Vent Systems:

It is acceptable to use mechanical draft systems, if the venting companies do the engineering calculations and make the necessary recommendations for fan size and flue vent diameter following the guidelines of NFPA 211/2006, pg. 211-13. Installation of such systems must also follow the mechanical drafting company's explicit installation and operation instructions.

The B-Vent type chimney system must be enclosed within a chase when installed in or passing through a living area where combustibles or people may come in contact with it. This is important to prevent possible personal injury or fire hazard.

Chimney Height Requirements:

Vent terminations must be located in accordance with the height and proximity rules of ANSI Z223.1 / NFPA 54 or CANCGA B149. These rules apply to vents of twelve inch (12") diameter and less and require minimum height in accordance with the roof pitch and a minimum of eight feet (8') distance from a vertical wall or other obstruction.

The location selected for the vent termination can have significant influence on proper draft performance of the appliance. On a windy day, obstructions such as nearby walls, trees or topographical features can create high pressure zones. The vent can become susceptible to windy conditions and tend to back draft when it is located in such high pressure zones.

In situations where the vent must be installed in a location that is less than eight feet (8') from a wall, parapet or other obstruction, the vent cap must be located at least two feet (2') above the obstruction.

For roofs from flat to 7/12 pitch the vent cap must be positioned at least one foot (1') above the roof surface.

As the roof pitch increases above 7/12 the roof begins to act much as a wall with high pressure zones being created by wind striking the roof itself. To compensate for this it is necessary to increase the termination height of the vent. The steeper the roof pitch the greater the vent height needed to overcome the high pressure zone. See chart below for minimum height requirements.

B-Type Vent Termination Chart (Figure 23)

(For 10 inch (10") diameter and smaller B-Type Vent)

Roof Pitch	Minimum Height (H)
Flat Roof up to 7/12	1 foot
over 7/12 up to 8/12	1.5 feet
over 8/12 up to 9/12	2 feet
over 9/12 up to 10/12	2.5 feet
over 10/12 up to 11/12	3.25 feet
over 11/12 up to 12/12	4 feet
over 12/12 up to 14/12	5 feet
over 14/12 up to 16/12	6 feet
over 16/12 up to 18/12	7 feet
over 18/12 up to 20/12	7.5 feet
over 20/12 up to 21/12	8 feet

Flush Wall Finish Detail

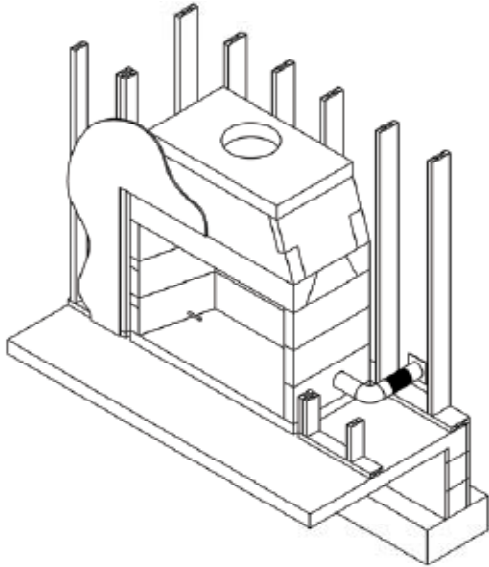

Figure 24

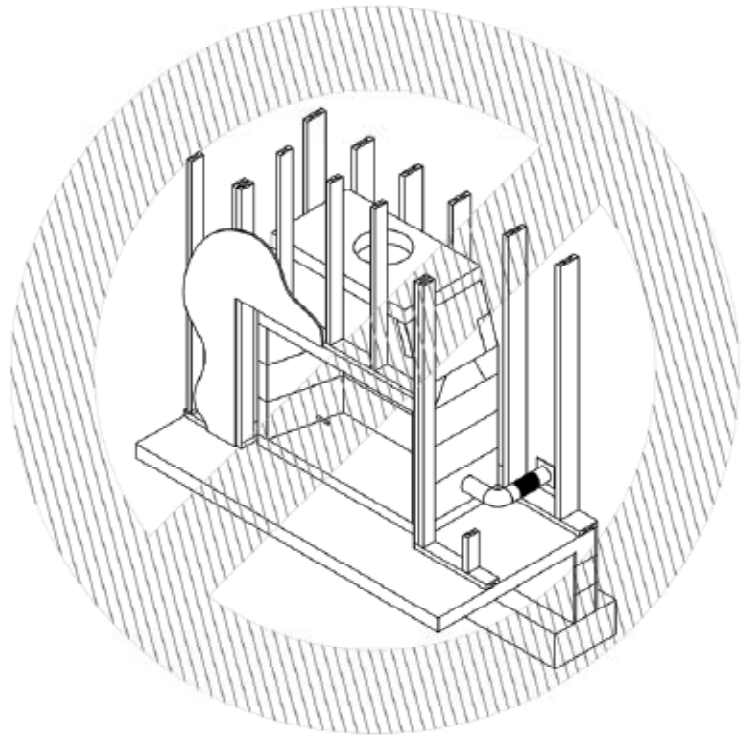

Figure 25

IBVs are designed to be installed so that the rough front face of the Isokern firebox and smoke dome sit flush to the room face of the rough framing members that create the room wall finish.

Important: Do not build a combustibile frame wall in front of the IBV firebox / smoke dome assembly. (Figure 25)

Wall Framing for the room wall where the IBV is set must not be placed across the front face of the IBV firebox and smoke dome assembly.

Clearance to Drywall: Drywall can be placed directly in contact with the front of the IBV firebox and smoke dome. (Figure 24) With the Isokern firebox/smoke dome set flush with the interior face of wall framing, drywall can be hung on the framing members and pass across the face of the IBV smoke dome and in contact with it. If necessary, the drywall can be affixed to the face of the Isokern smoke dome with drywall screws, maximum length one inch (1") - do not use nails.

The drywall must be cut back a minimum of two inches (2") from the sides of the firebox opening and eight inches (8") back from the top of the IBV firebox opening, leaving IBV material exposed around the face of the IBV firebox opening. These drywall cut back areas will be filled with grout in conjunction with the installation of the required fire brick lining requirements.

Required Clearances (when sheathing protrudes beyond front of firebox)

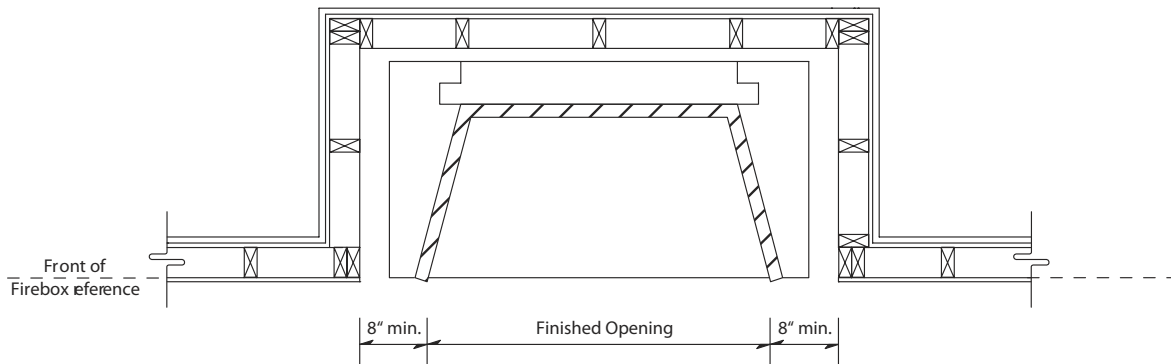

Figure 26

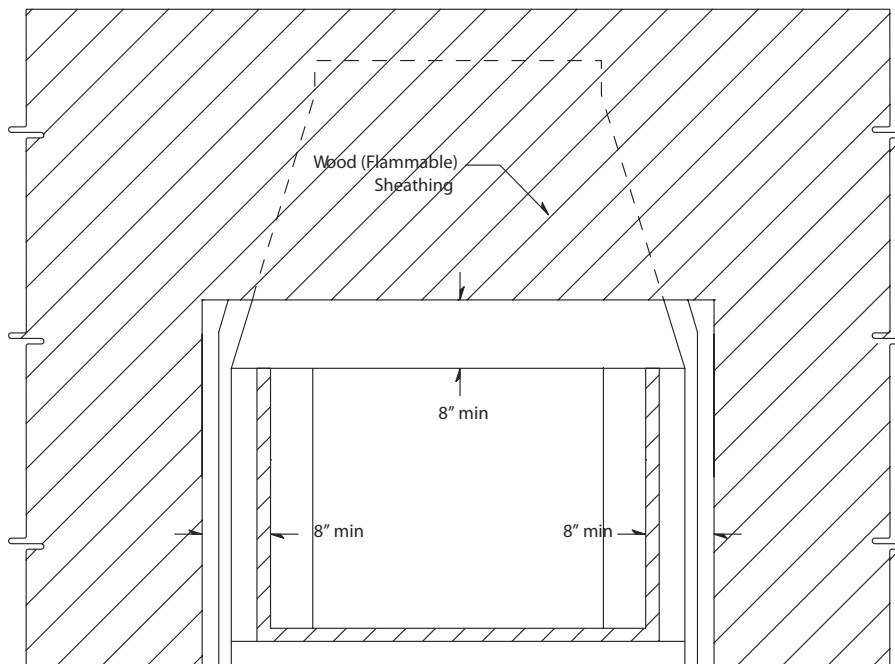

Figure 27

Combustible wood sheathing such as plywood and particle board may be used to cover the front face of the Isokern smoke dome and be in direct contact with it. Application of such combustible sheathings must assure that the sheathing is held a minimum of eight inches (8") away from each side of the finished fireplace opening and a minimum of eight inches (8") inches above the top of the finished fireplace opening. (Figure 26 & 27)

Do not attempt to build a combustible framed wall in front of the IBV unit.

If combustible wood sheathing is installed across the face of the Isokern smoke dome front be sure that when the required noncombustible finished facing materials are applied directly to the front of the IBV, that no gaps or voids are left behind the finished facing materials. Completely seal the required noncombustible finished facing materials directly to the Isokern unit with Earthcore Mortar or other noncombustible grout.

See page 28 for clearance to combustible finish trim. See page 22 for clearance to drywall.

Flush Wall Fire Brick Finish Detail

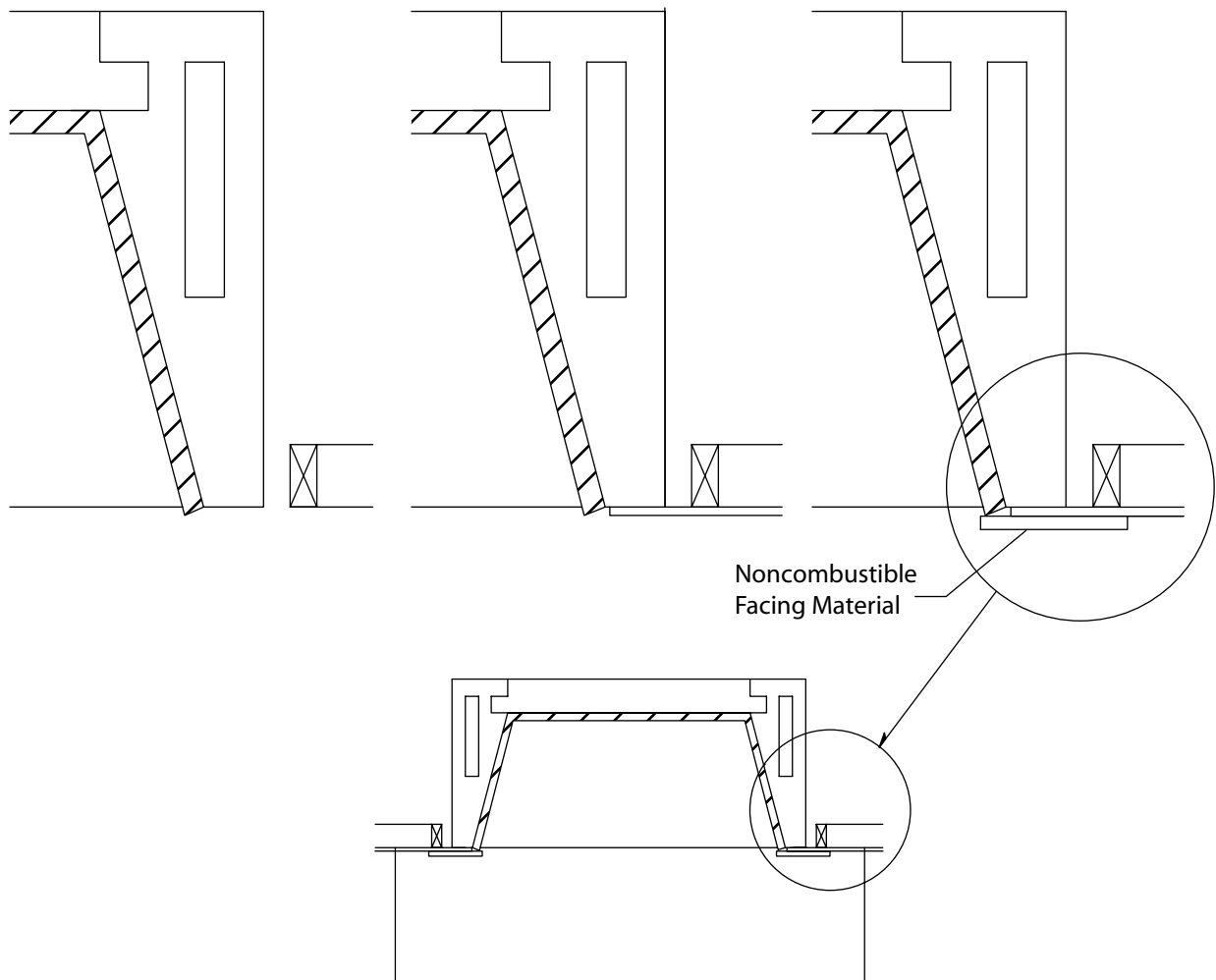

Figure 28

Recommended Fire Brick Detail: With drywall crossing over the face of the IBV smoke dome assembly (as previously described on page 22), to cover the exposed drywall thickness as well as to aid in the overall fit and finish of the IBV front, it is recommended, when installing the required fire brick lining to the interior of the firebox, that the leading edge of the fire brick - at the floor and at the side walls of the firebox - project into the room so that the fire brick is finished flush with the room's finished drywall surface.

This method of fire brick application, as shown above (Figure 28), allows the fire brick lining to cover the thickness of the drywall room finish. Also, with fire brick set in this fashion the code required noncombustible finish facing material (see page 28) can be set tight against the fire brick at the sides of the fireplace opening and at the same time lay flat against the finished wall surface.

Finish Facing Detail

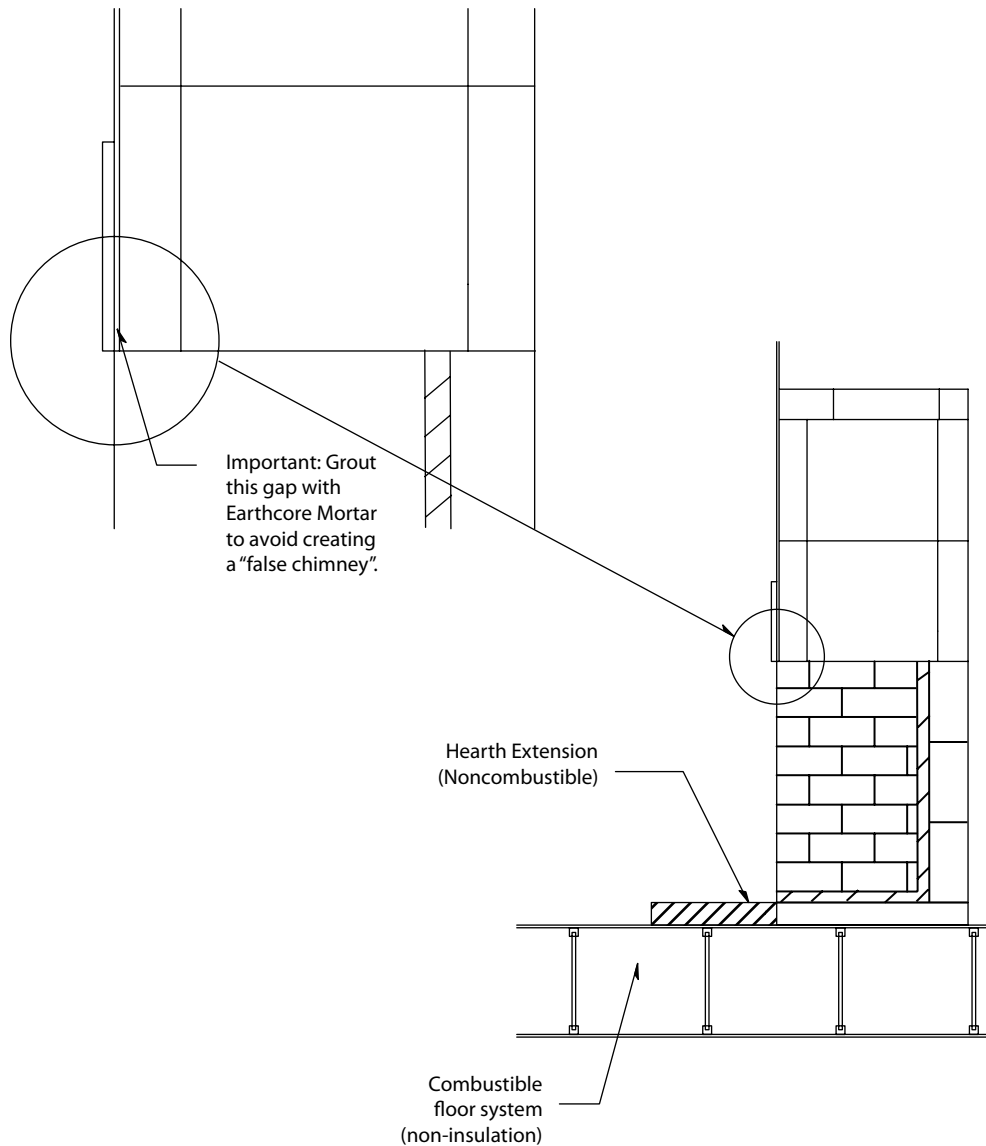

Figure 29

Important: Since there is no fire brick set along the top of the IBV firebox opening, when setting the noncombustible facing material (code required and supplied by others) onto the drywall across the top of the firebox opening there will be a gap between the back of the noncombustible finish material and the rough front face of the Isokern Smoke Dome (Figure 29).

Be sure to fill this gap with Earthcore Mortar (or similar noncombustible grout) in conjunction with placement of the code required noncombustible finish facing material that is set across the top of the firebox opening.

WARNING: Avoid false chimneys.

Important: Failure to seal any gaps between the front face of the IBV and the back of the noncombustible finished facing material will create what is known as a "false chimney" or "secondary chimney". A "false chimney", in this case is the narrow gap (mentioned above) between the back of the noncombustible facing material at the top of the firebox opening and the rough front of the IBV smoke dome. If left unfilled this gap creates a "false chimney" which can cause a fire hazard by drawing considerable heat out of the firebox and into the space behind the noncombustible finish facing and from there up into the wall cavity behind the drywall or other sheathing material that houses the Isokern fireplace.

Interior Full Masonry Veneer Finished Fireplace Fronts

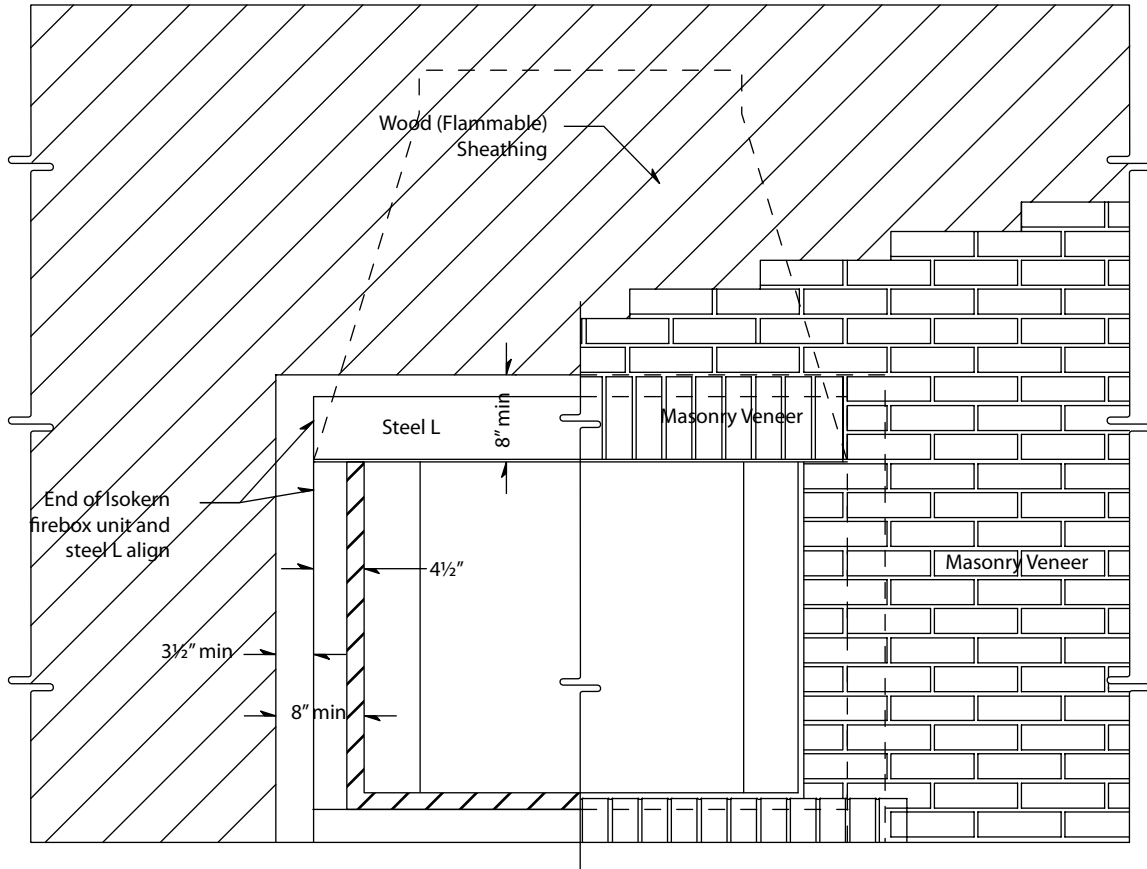

Figure 30

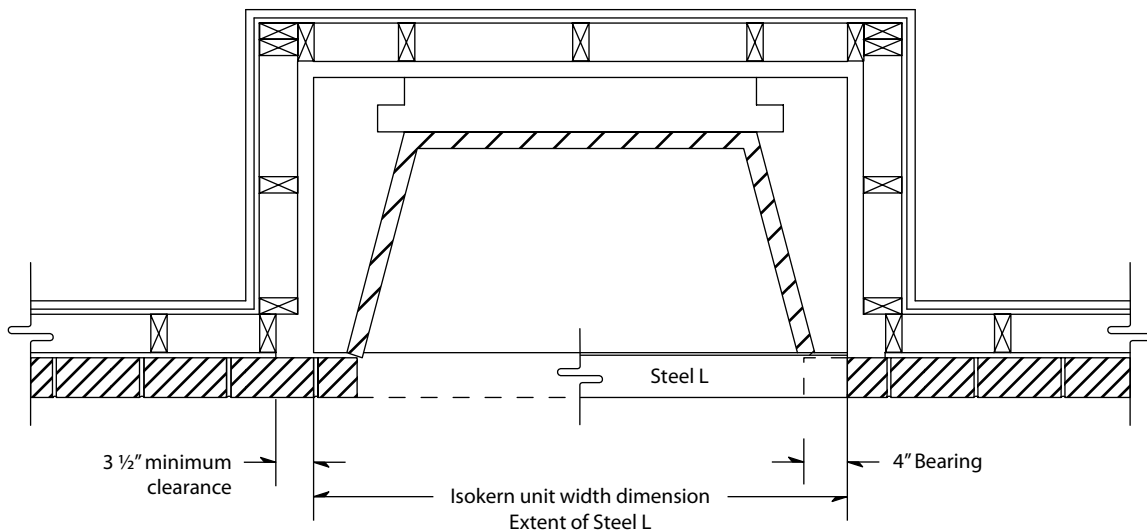

Figure 31

Interior Full Masonry Veneer Finished Fireplace Front Details

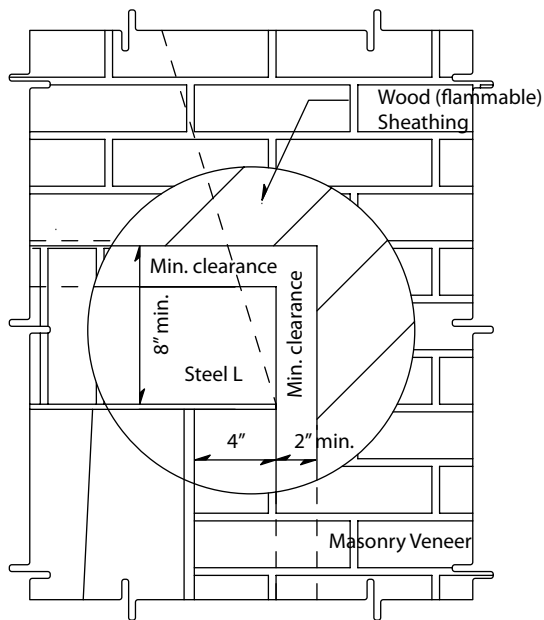

Figure 32

Brick, stone or other full masonry veneer finished fronts to IBVs are possible. Special attention is required with regards to: (1) the placement of the proposed masonry veneer facing and its interface with the IBV fire brick lining, and (2) the masonry veneer and clearance to combustible framing and sheathing from any and all steel "L" supports used in the masonry veneer around the front of the IBV, behind the veneer facing.

Any proposed brick, stone or other full masonry veneer facing must have sufficient foundation to support the full weight of the veneer. Check with local structural engineer for review of loads prior to construction.

The veneer facing, when installed, must present a tight seal with the leading edge - the room face edge - of the IBV fire brick lining at the sides of IBV firebox opening.

A steel "L" (maximum four inch (4") x six inch (6")) will need to span the top of the finished fireplace opening to carry the full masonry veneer over the IBV firebox opening. (Figure 32 & 33)

This steel "L" should have about four inch (4") end bearing. This bearing surface shall be provided in the veneer work. (Figure 32)

It is important that the steel "L" is set in a mud joint, tight against the Isokern smoke dome front to avoid creating a "false chimney" between the back of the steel "L" and the front face of the smoke dome. (Figure 33)

Steel "L" or angles used to support masonry veneer as it spans the Isokern firebox opening must, in all cases have two inch (2") clearance to all combustible materials.

Note:

1. The vertical leg of the steel "L" cannot exceed six inches (6"). (Figure 32)

Important: Combustible sheathing must be kept a minimum of eight inches (8") away from the IBV firebox opening top and sides.

WARNING: Combustible framing members, normally allowed at zero inch (0") clearance to the sides of the Isokern firebox must be moved to at least two inches (2") clearance to the firebox side wall in order to maintain two inch (2") clearance to the steel "L" to avoid a potential fire hazard.

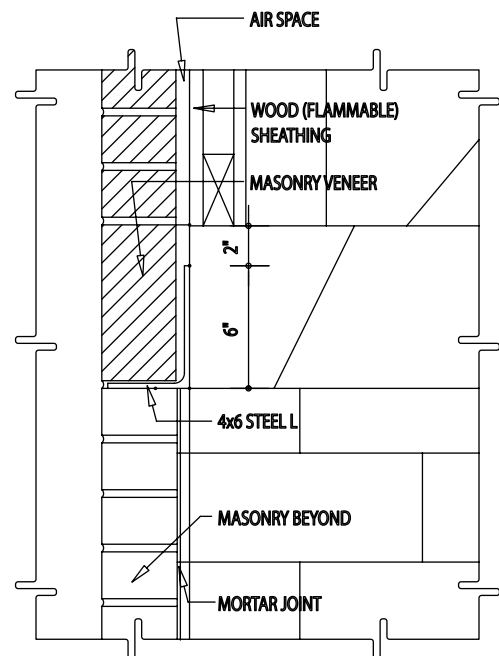

Figure 33

Combustible Finished Facing Requirements & Clearance to Combustible Trim

Mantle and Mantle Shelf Clearances:

All combustible trim projecting less than one and one-half inch (1 1/2") must be kept eight inches (8") from the sides of the fireplace opening. All combustible trim projecting more than one and one-half inch (1 1/2") must be kept twelve inches (12") from the fireplace opening. (Figure 36)

Parts of the combustible mantle assembly located along the sides of the fireplace opening, which project more than one and one-half inches (1-1/2") from the face of the fireplace, shall have additional clearance equal to that of the projection.

Parts of the combustible mantle assembly located above and projecting more than one and one-half inches (1-1/2") from the fireplace opening shall not be placed less than twelve inches (12") from the top of the fireplace opening. (Figure 35)

Adjoining Walls: Side walls and walls to rooms adjoining the Isokern fireplace installation cannot be closer than twenty four inches (24") to the finished fireplace opening. (Figure 36)

Ceilings: The minimum clearance from the top of the fireplace opening to a ceiling is forty-two inches (42"). (Figure 34)

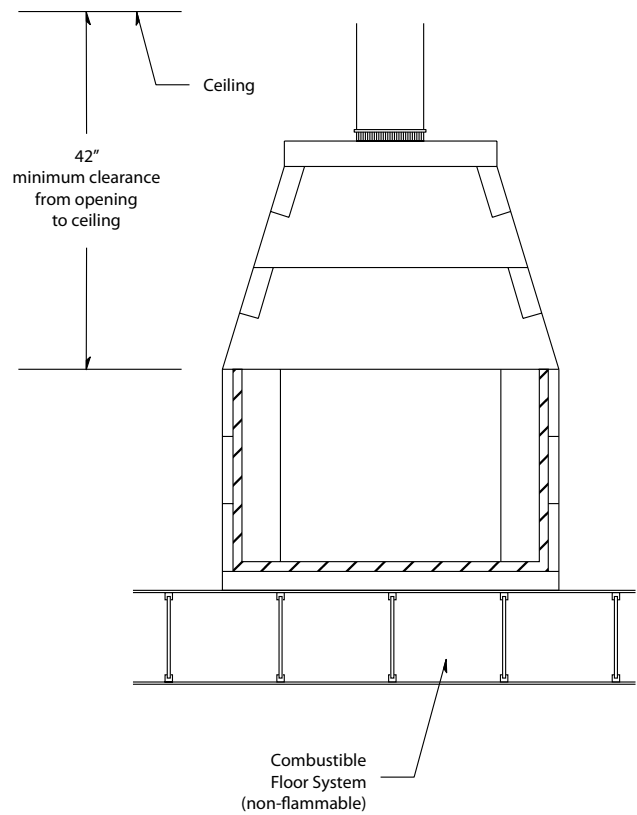

Figure 34

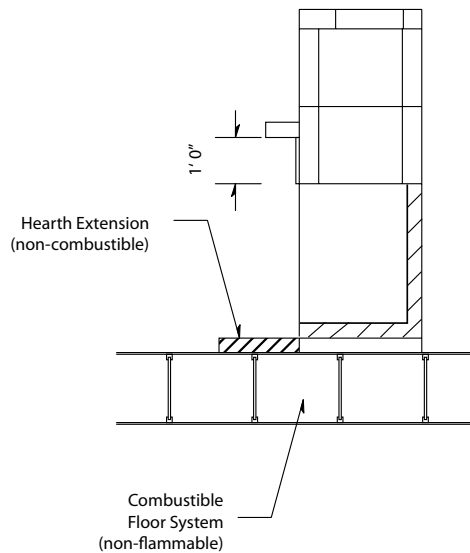

Figure 35

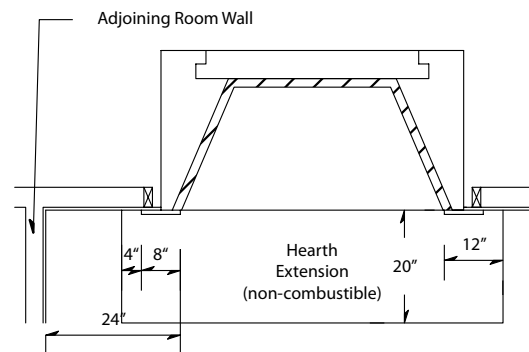

Figure 36

ISO-FLAMES Gas Log Burner Installation

The gas control valve is installed on the right side of the ISOFLAMES gas log burner. If the gas supply line comes into the left side of the fireplace, the gas supply line must continue to the right side of the fireplace (as close to the rear fire box wall as possible) and terminate behind the gas valve inlet using rigid 1/2" black iron pipe. At this point only the 3/8" aluminum manifold can be used to complete the connection to the gas control valve. It may be necessary to cut and reflare the aluminum manifold to the desired length for proper positioning of the burner pan.

Step 1. Remove all ashes and debris from fireplace.

Step 2. Be sure gas control valve to fireplace is in the OFF position.

Step 3. Place the ISOFLAMES gas log burner in fireplace with grate spokes toward front of fireplace and vertical baffle should be in line with chimney.

NATURAL GAS OR LIQUID PROPANE

A. Apply pipe thread sealer to gas supply line coming into fireplace and install 3/8" x 1/2" brass supply fitting; tighten.

B. Install longer end of flared aluminum manifold with 3/8" brass flair nut to 3/8" x 1/2" brass supply fitting connected to gas supply line coming into fireplace, and shorter end to rear of gas control valve; tighten.

C. When connections are complete, NEVER TEST FOR GAS LEAKS WITH A LIT MATCH OR FLAME. Slowly turn gas control valve to the ON position and use 50/50 soap and water solution with a toothbrush or small paint brush over all gas connections. A leak will be evident by observation of bubbles on gas connections. If bubbles are observed, retighten leaking gas connectors.

Gas Log Installation:

See pages 36 & 37. Logs are reversible for either a classic bark look, or a rugged split look.

WARNING: Failure to position items in accordance with these diagrams or failure to use only parts specifically approved with the ISOFLAMES gas log system may result in property damage or personal injury.

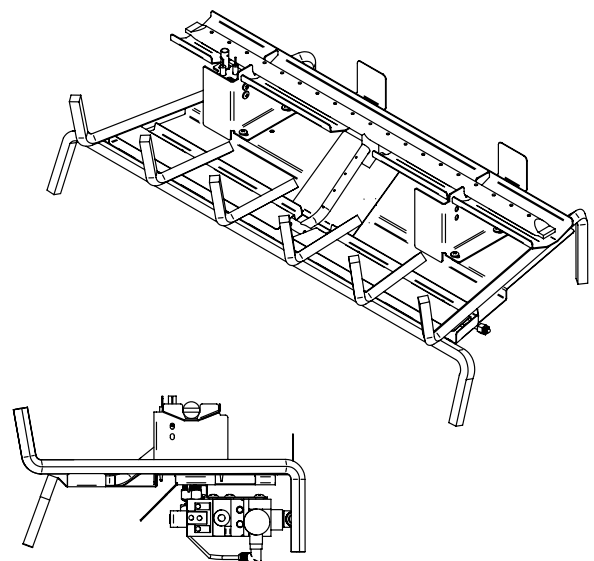
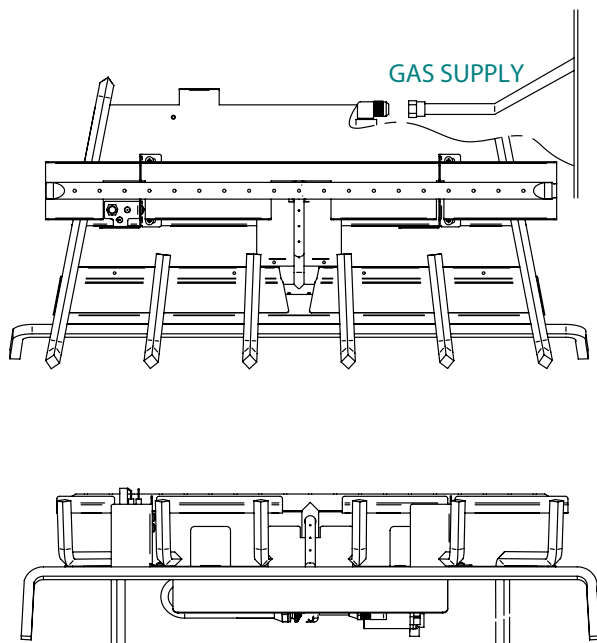

ISOFLAMES® Gas Log System

OWNER'S MANUAL
Installation & Operating Instructions
ISOFLAMES Gas Log Systems
24" - 30"

THE ISOFLAMES GAS LOG SYSTEM MUST BE INSTALLED BY A LICENSED PLUMBER OR GAS FITTER AND IN ACCORDANCE WITH ALL LOCAL/STATE/FEDERAL CODES.

WARNINGS

1. READ THESE INSTRUCTIONS COMPLETELY BEFORE USING THE ISOFLAMES GAS LOG SYSTEM.
2. The ISOFLAMES gas log system must be installed in the Isokern B-Vent (IBV) fireplace series.
3. Minimum fireplace opening must adhere to the size chart listed on page 32 of this owner's manual.
4. Fireplace must adhere to: noncombustible hearth extending minimum twenty inches (20"), noncombustible material extending a minimum of twelve inches (12") above the top of the fire box opening; noncombustible materials extending minimum eight inches (8") on both sides of fireplace opening.
5. If the information in this owner's manual is not followed exactly, a fire or explosion may result causing property damage, personal injury or loss of life.
6. Do not store or use gasoline or other flammable vapors and liquids in the vicinity of the ISOFLAMES gas log system.
7. What to do if you smell gas:
 - A. Do not try to light the ISOFLAMES gas log system or any appliance.
 - B. Do not touch electrical switches or the telephone.
 - C. From your neighbor's telephone, call your gas supplier and follow the gas supplier's instructions.
 - D. If you cannot reach your gas supplier, call the fire department.
8. Improper installation, adjustment, alteration, service or maintenance can cause injury or loss of life. Refer to this owner's manual for assistance.
9. Do not install the ISOFLAMES gas log system in a manufactured home or mobile home.
10. **Installer: Leave this owner's manual for the consumer; consumer: save this owner's manual for future reference.**

General Information

Tools Required:

1. Adjustable wrench
2. 3/8" flaring tool
3. Open-end wrench (7/16")
4. Open-end wrench (3/4")
5. Pipe thread sealer (Non-hardening)
6. Slip-joint pliers (7")
7. Flat blade screwdriver
8. Pipe wrench (10")
9. 50/50 soap & water solution
10. Flashlight

System Contents:

The ISOFLAMES gas log system consists of the following items.

If any of the items below are damaged or missing, call us directly at (800) 642-2920 and we will promptly answer your call.

1. ISOFLAMES gas log burner with remote control valve
2. 3/8" x 1/2" brass supply fitting
3. Flared aluminum manifold with 3/8" brass flare nut
4. Embers
5. Gas Logs
6. Twig gas logs
7. Lava rock
8. Optional damper stop
9. Optional 3/8" x 1/2" brass elbow
10. Hand-held remote control
11. Wall Switch (Optional)

Safety Instructions Prior To Installation

WARNING:

1. When used without fresh air, the ISOFLAMES gas log system may give off carbon monoxide, an odorless and poisonous gas. You must make adequate air supply accessibility or provisions for combustion and ventilation; carbon monoxide poisoning may lead to death.
2. Check the ISOFLAMES gas log system for proper gas type; the gas type will be marked on the rating plate. A liquid propane ISOFLAMES gas log system must have a standing pilot; a manual valve or a key valve is never to be used with liquid propane.
3. The installation and provisions for combustion and ventilation air must conform with the National Fuel Gas Code, ANSI Z223.1/NFPA 54, or the CSA B 149.1, National Gas and Propane Installation Code.
4. Solid-fuels must not be burned in a fireplace where the ISOFLAMES gas log system is installed.
5. Fireplace chimney must have a permanent vent opening to the atmosphere of not less than ten inch inside diameter. (10")
6. Fireplace must adhere to: noncombustible hearth extending minimum twenty inches (20"), noncombustible material extending a minimum of twelve inches (12") above the top of the fire box opening; noncombustible materials extending minimum eight inches (8") on both sides of fireplace opening.
7. Minimum fireplace opening must adhere to the size chart listed on next page:

Safety Instructions Prior To Installation/Pilot Assembly Wire Diagram

ISOFLAMES BURNER	FIREPLACE WIDTH	FIREPLACE HEIGHT MINIMUM	BTU NATURAL GAS	BTU LIQUID PROPANE
24"	IBV 36"	30"	50,000	50,000
30"	IBV 46"	30"	65,000	65,000

8. Gas supply pressures:

GAS SUPPLY PRESSURE	NATURAL GAS	LIQUID PROPANE
Minimum inlet gas supply pressure for the purpose of input adjustment	5" w.c.	10.5" w.c.
Maximum inlet gas supply pressure	7" w.c.	13" w.c.
Manifold pressure	3.5" w.c.	10" w.c.

The ISOFLAMES gas log system's gas control valve must be disconnected from gas supply piping system during any pressure testing of the ISOFLAMES gas log system at test pressures in excess of 1/2 psi (3.5kpa). The ISOFLAMES gas log system must be isolated from the gas piping system by closing the gas control valve during any pressure testing of the gas supply piping system at test pressures less than 1/2 psi (3.5kPa).

9. All ISOFLAME gas log assembly systems (whether with Safety Pilot Valve or Remote Pilot Valve) are equipped with a 1/8 NPT plugged tapping, accessible for test gage connection, immediately upstream of the gas supply connection to the appliance.

10. The ISOFLAMES gas logs are convertible if done by a certified gas technician.

11. Keep the ISOFLAMES gas log system's area clear and free from combustible materials such as gasoline and other flammable vapors and liquids.

12. Do not use the ISOFLAMES gas log system if any part has been immersed in water. Call a qualified service technician to inspect the ISOFLAMES gas log system. Replace any part of the ISOFLAMES gas log system that has been immersed in water.

13. The fireplace chimney and flue needs to be inspected and cleaned once a year by a qualified service technician.

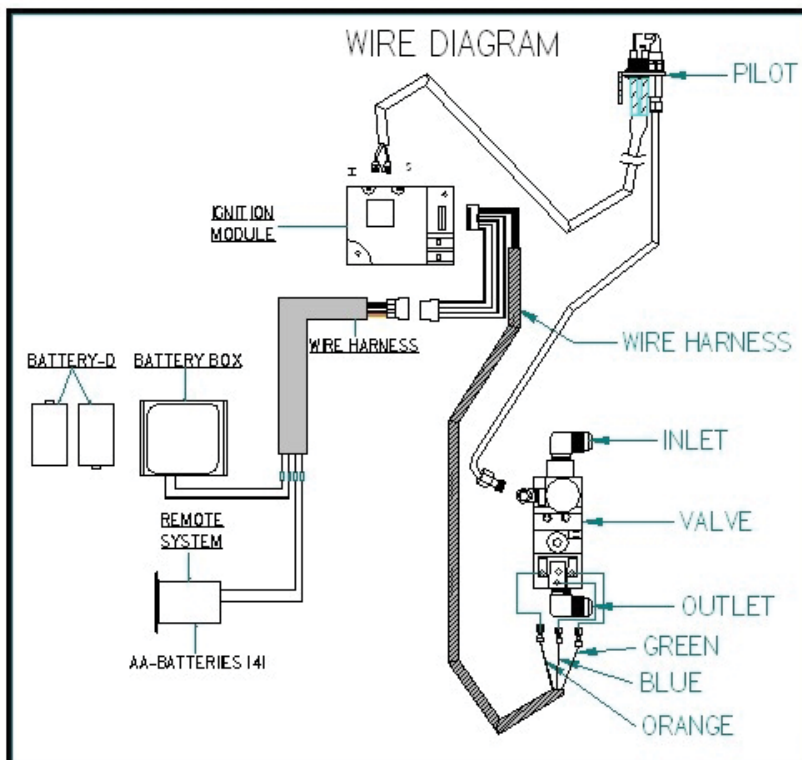

Isoflames Gas Log Burner Installation

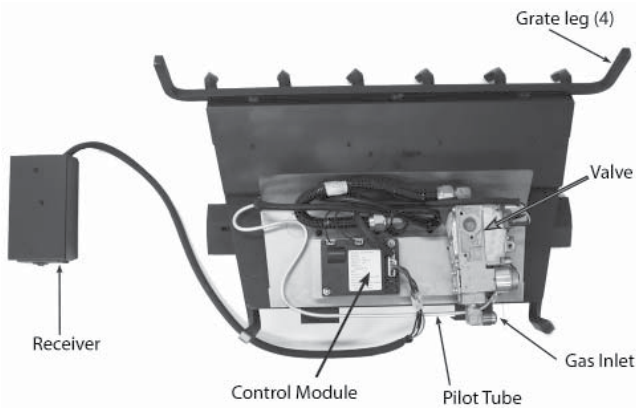

Fig. 1 - Burner System Detail - Bottom View

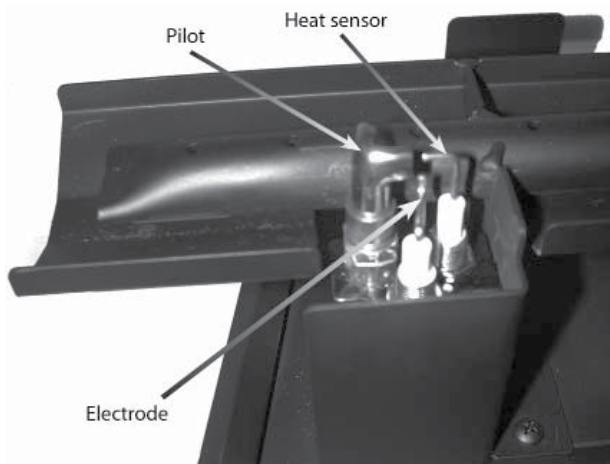

Fig. 2 - Burner System Detail - Pilot Assy

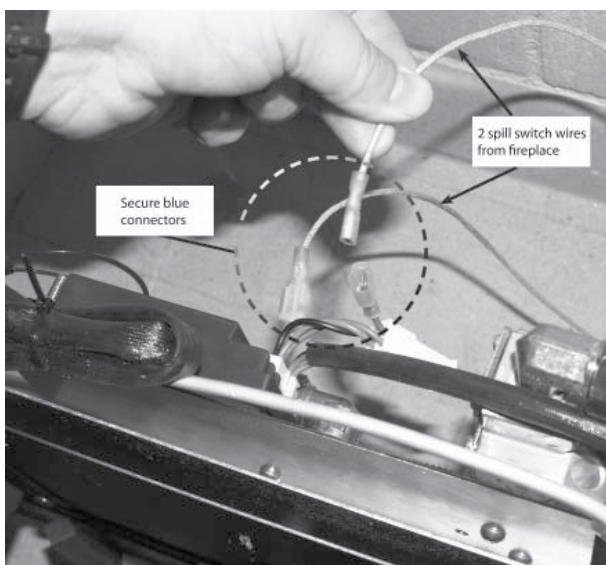

Fig. 3 - Connect spill switch wires

1. MAKE SURE THE FIREPLACE GAS SUPPLY IS TURNED OFF.
2. Place the burner system in the fireplace. Rest it upward, on the front grate fingers to expose and allow access to the bottom rear of the burner controls.
3. Locate the two spill switch wires coming out of the hole in the lower right side of the fireplace. Connect the spill switch wires to the two free wires (coming from the control module) located at the rear of the burner system (see Fig. 3).
4. Place the burner system down so that it rests on the burner grate legs. Center the burner toward the rear of the fireplace. (Reference Fig. 5 for orientation.)
5. Locate the gas-supply stub inside the fireplace and remove the cap, if attached (see Fig. 4).
6. Use pipe compound resistant to all gases or Teflon tape to attach the supplied elbow to the gas-supply stub. Then attach the flex connector (coming off of the burner system) to the elbow (see Fig. 4).

Gas Log Burner Installation (cont.)

Isokern Gas Burner Installation Instructions

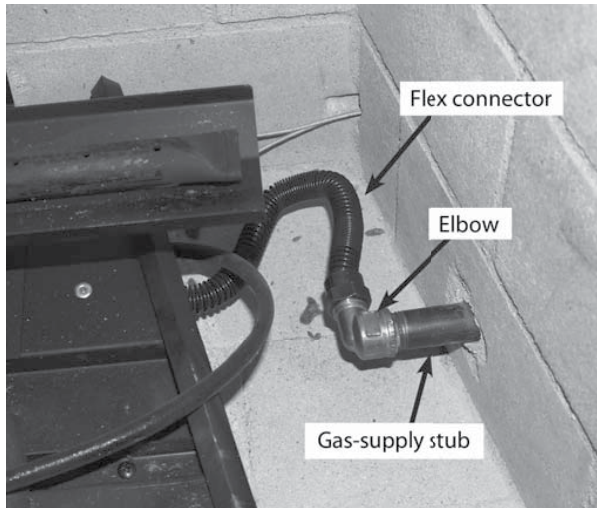

Fig. 4 - Connect gas supply

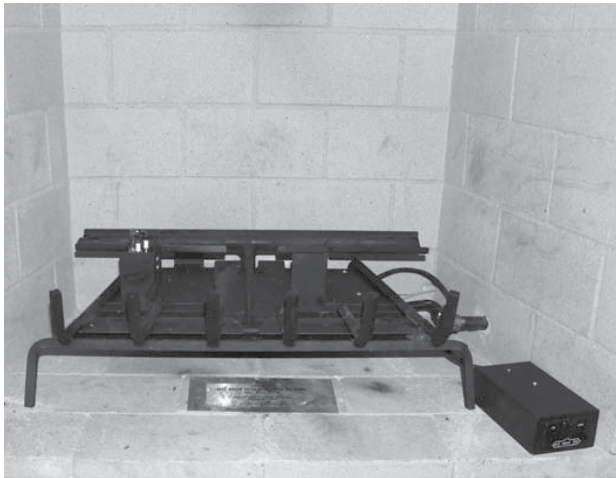

Fig. 5 - Remote box location

7. LEAK TEST: Turn on the fireplace gas supply, and test at all connections for leaks using the appropriate soapy water solution. If bubbles appear, a leak is present. Turn off the gas and tighten at all connections. Repeat until no leaks are present. If a leak persists, turn off the gas supply and contact the local gas company or dealer. NEVER USE A FLAME TO CHECK FOR LEAKS.
8. Place the remote receiver box at the right front corner of the fireplace. Be sure to run its wire in between the two grate legs on the right side of the burner system, and that the wire remains away from the burner system and its flame during operation. (See Fig. 5.)
9. Spread the supplied lava rock on the floor of the firebox around the front and sides of the burner system. The lava rock may be placed around the rear, top, and left side of the remote receiver box. Leave the front of the box clear for control access.

DO NOT place any lava rock on the burner system, or behind it.
10. Proceed to the "ISO-Flames Gas Log Assembly Instructions" section for ember and log placement.

ISOFLAMES Gas Log Assembly Instructions



This instruction contains suggested log placement for the ISO-FLAMES log set. Some flexibility is possible in log placement to suit your individual preference provided excessive sooting does not result from flames striking the logs too directly (see important below). The suggested log placement will allow for superior flame pattern and appearance. Please read these instructions completely and carefully before beginning.

Important: Although there is some flexibility with the log placement, adequate spacing between the logs is **NECESSARY** and **MUST** be maintained for best performance. Some carbon build up (sooting) may occur where the flames strike the logs, and should not be a concern, unless excessive. If sooting is excessive, rearrange the top logs to allow more opening for the flame.

WARNING: Use only parts specifically approved for use with this gas log set. Failure to do so may result in property damage or personal injury. Check with your local dealer if you need more information.

CAUTION: Burn hazard! Logs will remain hot for some time after use. If you need to reposition any log to maintain the proper layout, use heat resistant gloves or allow logs adequate time to cool before handling.

ISOFLAMES Gas Log Assembly Instructions (cont.)

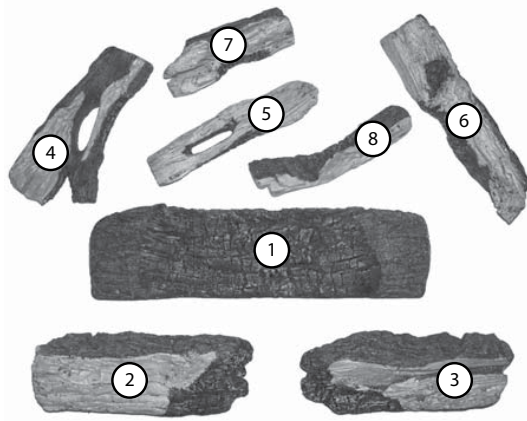

Fig. 2-1

Note: Highlighting added to improve clarity.

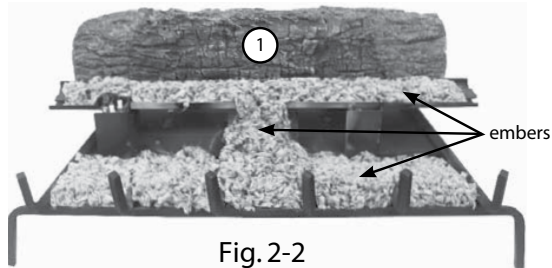

Fig. 2-2

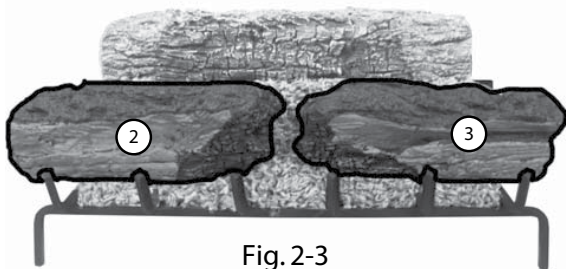

Fig. 2-3

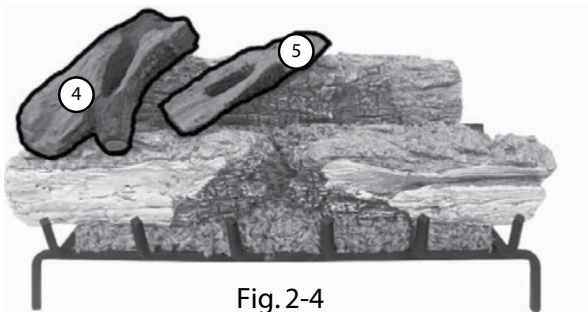

Fig. 2-4

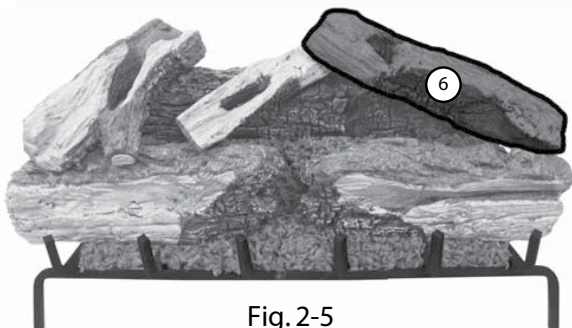

Fig. 2-5

LOG LIST

1. Bottom rear log
2. Bottom left log
3. Bottom right log
4. Middle left log
5. Middle center log
6. Middle right log
7. Top left log
8. Top right log

LOG PLACEMENT

Each log in this gas log set is numbered here to assist in the log placement procedure.

1. Prior to log placement, spread the provided embers evenly over the designated areas on the burner, as shown in Fig. 2-2.
2. Set the bottom rear log #1 at the rear of the grate (Fig. 2-2). Center the log, with its back up against the burner tabs.
3. Set the bottom left and right logs #2-3 at the front of the burner with the charred ends facing inward. Leave a small gap in between the two charred ends. (Fig. 2-3). Center the logs, with their backs up against the burner tabs. (The bottom left log is longer and will slightly stick outward more than the bottom right log.)
4. Position the middle center log #4 on the left side of the log set, resting on logs #1 and #2 as shown. Position the middle center log #5 in a similar manner (with more of an angle), toward the center of the log set. (Fig. 2-4.)
5. Position the middle right log #6 on the right side of the log set, resting on logs #3 and #5 as shown in Fig. 2-5.
6. Position the top left log #7 at a slight angle on top of logs #4 and #5 as shown. The charred end should rest downward. Complete log placement by positioning the top right log #8 at an angle on top of log #6, with the bottom end resting in between the charred section of logs #1 and #2. (Fig. 2-6.)

Final Log Placement

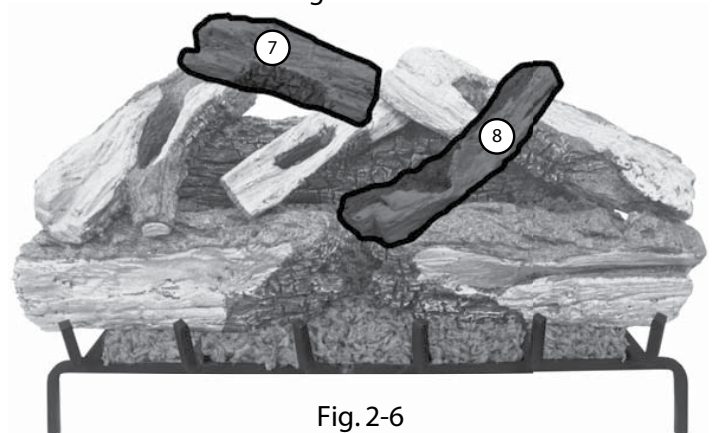

Fig. 2-6

Safety Instructions Before Lighting & Lighting Instructions

FOR YOUR SAFETY READ BEFORE LIGHTING

WARNING: If you do not follow these Instructions exactly, a fire or explosion may result causing property damage, personal injury or loss of life.

A. This appliance has a pilot which must be lit by hand. When lighting the pilot follow these instructions exactly.

B. BEFORE LIGHTING smell all around the appliance area for gas. Be sure to smell next to the floor.

WHAT TO DO IF YOU SMELL GAS

- Do not try to light any appliance
- Do not touch any electric switch; do not use any phone in your building;
- Immediately call your gas supplier from a neighbor's phone. Follow the gas supplier's instructions.
- If you cannot reach your gas supplier, call the fire department.

D. Do not use this appliance if any part has been under water. Immediately call a qualified service technician to inspect the appliance and to replace any part of the control system and any gas control which has been under water.

LIGHTING INSTRUCTIONS

1. STOP! Read the safety information on the other side.
2. Turn "OFF" any electrical appliance
3. When operated with remote system flip the receiver control to the "Remote" position, and turn unit "ON" and "OFF" by using the remote transmitter.
4. Flip the receiver switch to the "ON" position when manually operated. This transmits a rapid series of sparks at the pilot head and will ignite the gas.

- Sparks cease when the pilot flame is lit and stable. After a short time, the pilot will then light the main burner.

CAUTION: IF THE BURNER DOES NOT IGNITE WITHIN 20 SECONDS, STOP WAIT 5 MINUTES, THEN REPEAT STEPS 2. THRU 4. ABOVE.

- Normally, the pilot should remain lit. If it goes out, repeat step 3 or 4.
- If the pilot will not stay lit after several tries, turn the wall switch to OFF (Fig.3) and call service technician or gas supplier.
- Periodically check the pilot for proper flame pattern (Fig. 1)

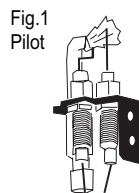

Fig.3



Fig.2



TO TURN OFF GAS TO THE APPLIANCE

1. Simply flip the receiver switch to the "OFF" position when manually operated. The gas flow will cease, and all the flames (main burner and pilot) will go out.
2. For remote operation, press the "OFF" button on the remote.

WARNING: Improper installation, adjustment, alteration, service or maintenance can cause injury or property damage. Refer to manual. For assistance or additional information consult a qualified installer, service agency or the gas supplier.

FOR YOUR SAFETY

Do not store or use gasoline or other flammable vapors or liquids in the vicinity of this or any other appliance.

100234

Lighting Instructions (cont.)

Important: The ISOFLAMES Series gas log system must be installed by a licensed plumber or gas fitter per code.

WARNING: For safe operation of the ISOFLAMES gas log system, a minimum inlet gas supply pressure of 5" w.c. is required for natural gas; minimum gas supply inlet pressure 10.5" w.c. is required for liquid propane.

Improper installation, adjustment, alteration, service or maintenance can cause injury or property damage. For assistance or additional information, consult a qualified service technician or the gas supplier.

The ISOFLAMES gas log system must be installed in an IBV only.

Minimum fireplace opening must adhere to the size chart listed on page 32 of this owner's manual.

Fireplace chimney must have a permanent vent opening to the atmosphere of not less than 10" diameter.

CAUTION: If you do not follow these instructions exactly, a fire or explosion may result causing property damage, personal injury or loss of life.

A. The ISOFLAMES gas log system has a pilot assembly and it must be lit by hand. When lighting the pilot, follow these instructions exactly.

B. Before lighting the pilot, smell for gas around the ISOFLAMES gas log system and next to the floor; gas can be heavier than air.

What to do if you smell gas:

1. Do not try to light the ISOFLAMES gas log system or any appliance.
2. Do not touch electrical switches or the telephone.
3. From your neighbor's telephone, call your gas supplier and follow the gas supplier's instructions.
4. If you cannot reach your gas supplier, call the fire department.

C. Open the Damper by moving the Damper Lever (located at the top right of the firebox opening) from left to right.

D. Do not use the ISOFLAMES gas log system if any part has been immersed in water. Call a qualified service technician to inspect the ISOFLAMES gas log system. Replace any part of the ISOFLAMES gas log system that has been immersed in water.

Reversible for different looks!



Oak



Split Oak

Troubleshooting & Maintenance

PROBLEM	REASON	SOLUTION
Pilot will not light	Air in gas supply line	Bleed gas supply line
	Pilot hood blocked	<ul style="list-style-type: none"> • Check for debris or dirt • Clean pilot
	Low gas pressure	<ul style="list-style-type: none"> • Check gas line for size and blockage
	Dirty pilot	<ul style="list-style-type: none"> • Pilot should be blue and hitting the thermocouple properly • Clean pilot
Pilot will not stay lit	Pilot hood not aimed at thermocouple	Pilot hood bent; replace pilot or angle pilot hood properly so pilot flame hits thermocouple 1/2" below tip of thermocouple
	Pilot line bent	Replace pilot line
	Thermocouple is loose	Tighten thermocouple nut at gas control valve
	Thermocouple cracked	Replace thermocouple
	Thermocouple worn out	Replace thermocouple
	Excessive down draft	<ul style="list-style-type: none"> • Install chimney cap • Outside Chimney too close to other peaks • Check chimney flue for proper height • Poorly designed chimney
	Gas log burner goes out	Low gas pressure; pilot fades
Thermocouple is loose		Tighten thermocouple nut at gas control valve
Thermocouple worn out		Replace thermocouple

Maintenance:

The ISOFLAMES gas log system will last a lifetime, but periodic maintenance (at least once a year) is recommended.

Can you clean it yourself? Yes you can if you have the proper training! Safety is of prime concern so we recommend that you call your Earthcore authorized dealer for proper maintenance. If an Earthcore dealer is unavailable, call us directly at 800 642-2920 and we will promptly answer your call.

ISOFLAMES Customer Service & Warranty

Customer Service

Earthcore Industries, LLC is committed to customer service and exceeding customer expectations. We are available Monday - Friday 8:30 AM to 4:30 PM EST toll free at 800 642-2920 to provide technical assistance and answer any questions you may have.

Warranty

THE WARRANTY MENTIONED HERE IS ONLY FOR THE ISOFLAMES GAS LOG SET.

Earthcore Industries 20+ years of success is the result of exceeding customer expectations and as Earthcore looks ahead, this principle remains at the core of Earthcore culture.

You have a ONE YEAR PARTS WARRANTY with Earthcore products.

If you should accidentally break a log, or if there is another issue you may have with the ISOFLAMES gas log system that is included with the IBV, please call your Earthcore Industries, LLC authorized dealer or call us directly at 800 642-2920.

It is important for you to register your ISOFLAMES gas log system with Earthcore. Please complete the warranty card included in this manual on page 40.

1. The ISOFLAMES gas log burner has a one year warranty against any performance defects.
2. The ISOFLAMES gas logs have a one year warranty against breakage; except breakage due to mishandling or negligence.
3. If the ISOFLAMES gas log burner was purchased with a gas control valve, the gas control valve has a one year warranty against any performance defects.
4. All painted surfaces that get wet due to rain, flooding, household pets, wild animals or birds, or get damaged due to negligence or disaster, have no warranty.
5. Embers and lava rock that get wet due to rain, flooding, household pets, wild animals or birds, or get damaged due to negligence or disaster, have no warranty.

Warranty Card

Please cut along dashed lines and send to:

Earthcore Industries, LLC
6899 Phillips Industrial Blvd.
Jacksonville, FL 32256

Attn: Technical Department

Warranty Card

Date of Purchase: _____

Name: _____

Address: _____

City, State: _____

Phone No. _____

Gas Log Burner Size: 24" 30" (Circle One)

Gas Control Valve Type: remote control safety pilot

Gas Type: Natural Gas or Liquid Propane (LP) - (Circle One)

Comments: _____

Purchased from: Name: _____

City, State: _____

Phone Number: _____

Installed by: Name: _____

City, State: _____

Phone Number: _____

OPTIONAL ISOFLAME WALL SWITCH INSTRUCTIONS

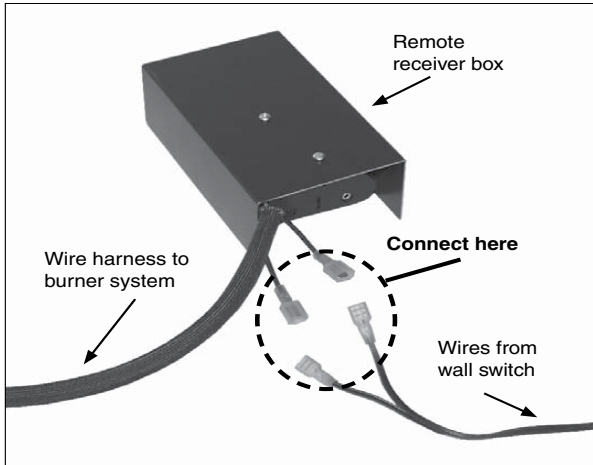

Fig. 1 - Connect wall switch to remote receiver box

Installation

1. Install the wall switch in the desired location within 15 feet from the burner system in the fireplace.
2. Run the supplied wire from the wall switch to the burner system.
3. Locate the two wires coming out of the rear of the remote receiver box, and connect them to the two wires routed in from the wall switch (see Fig. 1).

CAUTION: Do not supply 110V AC to the wall switch or burner system. This is a self contained circuit.

Operation

When using the wall switch to operate the burner system; the control located on the remote receiver box must be in the OFF position.

Alternately; when using the remote system, the wall switch must be in the OFF position.

Notes

Warranty & Disclaimer

Isokern Fireplace

Earthcore offers a lifetime warranty for all Isokern components, to be free from defects in materials that negatively affect system performance from the date of purchase, subject to the terms and conditions of this limited warranty.

This warranty covers only the above stated components, and NO WARRANTY, EXPRESS OR IMPLIED, EXTENDS TO ANY OF THE HARDWARE, FOOTING, VENTS, DUCTING, METAL FLUES, FIRE BRICK OR ACCESSORIES. THIS WARRANTY DOES NOT COVER DRAFTING, SMOKING OR PUFFING OF THE FIREPLACE SYSTEM. Factors beyond the manufacturer's control affect fireplace drafting, smoking, and puffing, and Earthcore cannot guarantee these aspects of performance.

If a component is found to be defective under the terms of this warranty the party to whom this warranty is extended shall, notify Earthcore, 6899 Philips Industrial Blvd, Jacksonville, Florida 32256, in writing, by registered mail, within thirty (30) days following the discovery of the defect within the lifetime warranty period. The notice shall contain (1) the date of purchase; (2) place of purchase; (3) address of installation; (4) name, address and phone number of the owner; and (5) a brief description of the defect.

Earthcore, or any division thereof, is not responsible for any labor costs or indirect costs incurred for the replacement of defective components.

Earthcore is not responsible for misuse or mishandling of components. Nothing in this warranty makes Earthcore, or any division thereof, liable in any respect for any injury or damage to the building or structure in which the fireplace or chimney system has been installed or to persons or property therein arising out of the use, misuse, or installation of properly manufactured ISOKERN product.

EARTHCORE, OR ANY DIVISION THEREOF, SHALL NOT BE HELD LIABLE FOR ANY INCIDENTAL OR CONSEQUENTIAL DAMAGES OR EXPENSES ARISING OUT OF THE USE OF THE FIREPLACES OR CHIMNEY SYSTEMS. ALL SUCH DAMAGES AND EXPENSES ARE HEREBY EXCLUDED.

This warranty is null and void when the fireplace or chimney systems are not installed pursuant to the installation instructions provided by Earthcore or local building codes have not been followed completely.

This warranty applies only to those fireplace and chimney systems installed in the continental United States, Alaska, and Canada. If any part of this warranty is found to be unenforceable, the remaining parts shall remain in force and effect.

EARTHCORE HEREBY DISCLAIMS ALL GUARANTEES AND WARRANTIES, EXPRESS OR IMPLIED, BEYOND THE WARRANTIES SET FORTH HEREIN.

earthcore[®]
INDUSTRIES, L.L.C.

6899 PHILIPS INDUSTRIAL BLVD. • JACKSONVILLE, FLORIDA 32256
TEL (904) 363-3417 • TOLL 1 (800) 642-2920 • FAX (904) 363-3408