

Factor	NG	LPG
Burner Type	35	35
Orifice	650	220
BTU Max.	30000	20000
BTU min.	17500	12500
Kw/h	8.8k	5.8k
Chimney DIA.	4X6	4X6
Manifold Pressure[w.c]	5.4	8
Efficiency rate	81	77

Glass Size Length\Width	570.5 X 620 mm	22 7/16" X 24 7/16"
Appliance Weigh	85kg	185lb

Appliance Location

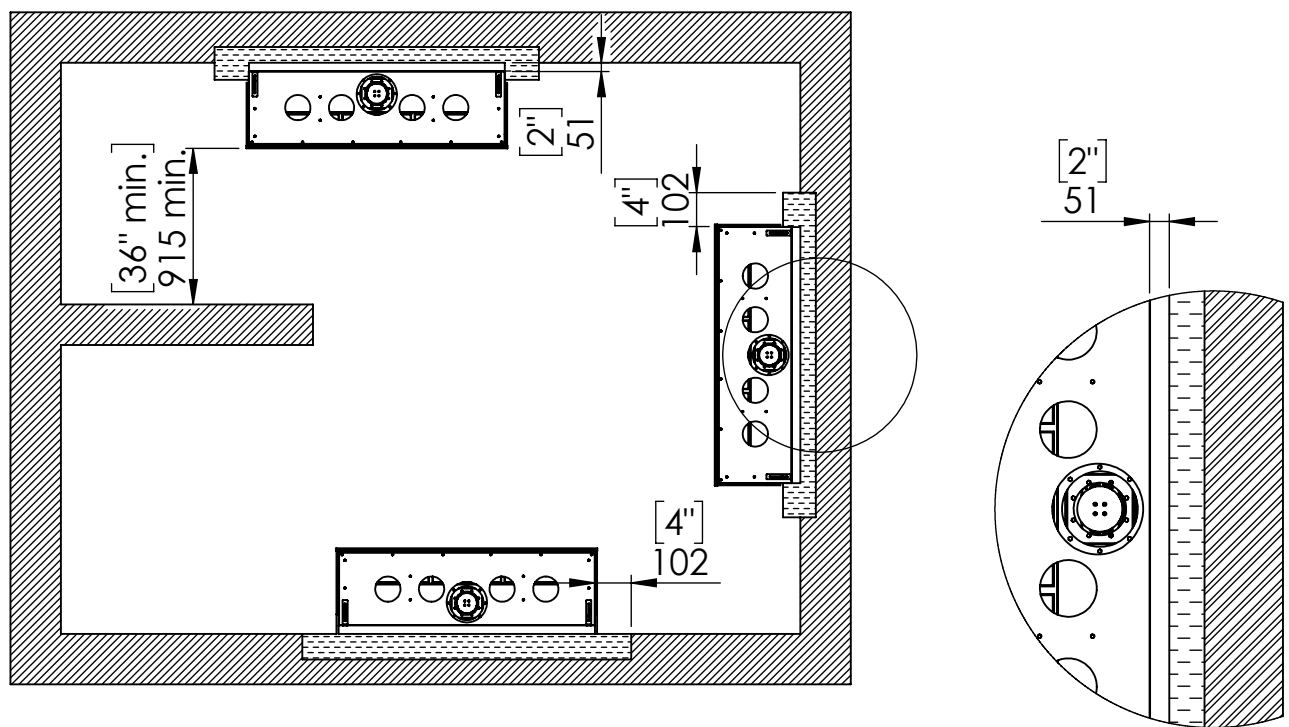

 Combustible Materials
 Non Combustible Materials



FLARE Double Corner 25

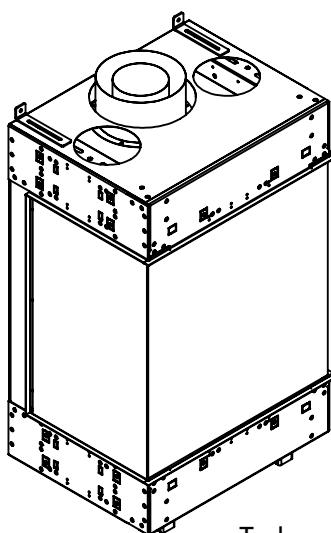
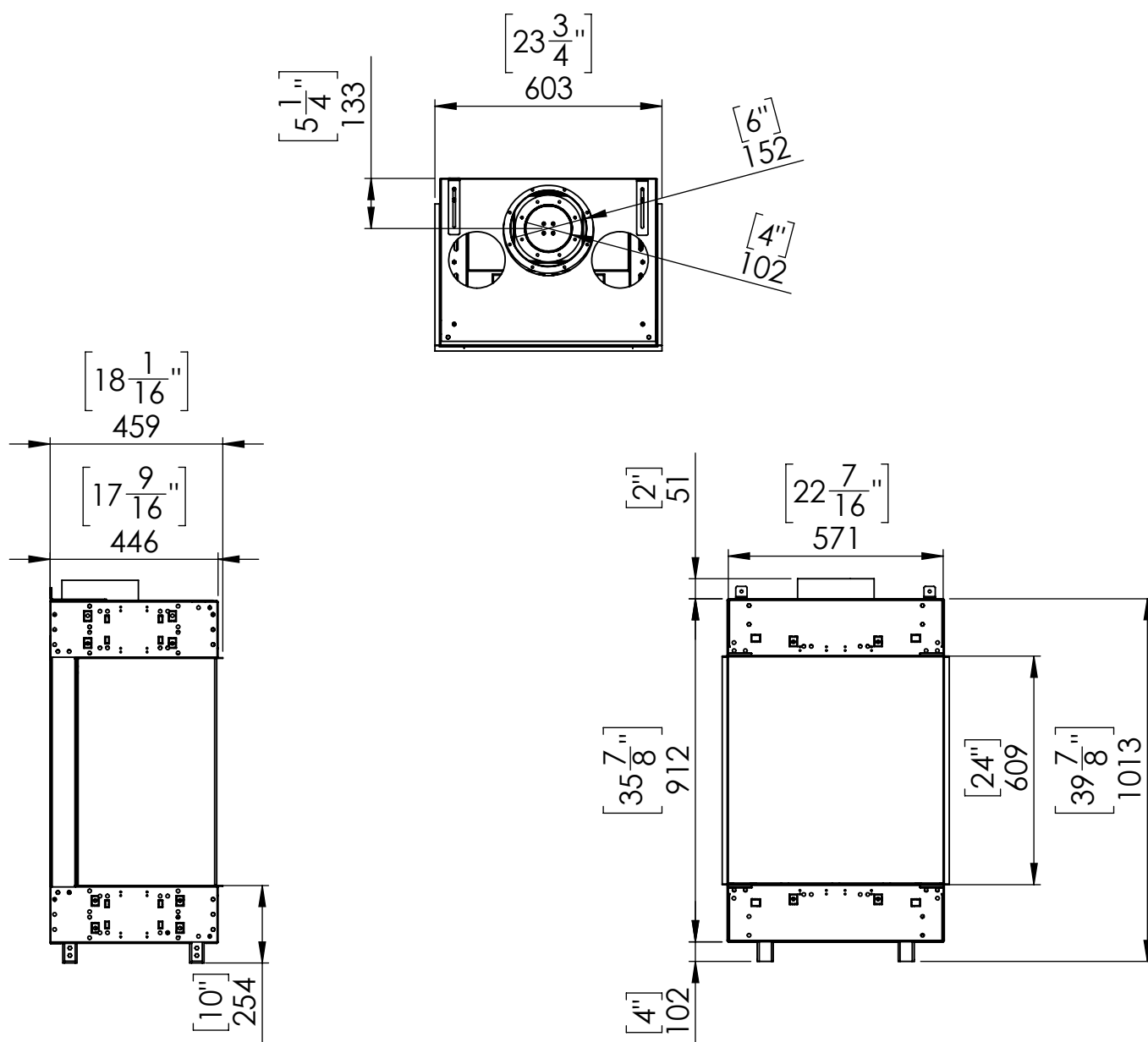

Telescopic leg ranges
(from bottom of glass): 10"-19"

Flat Installation

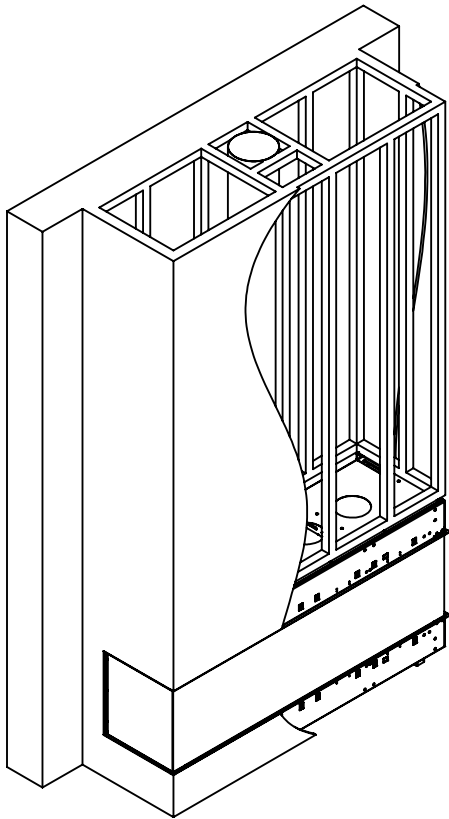

Step 1 - Basic Framing :

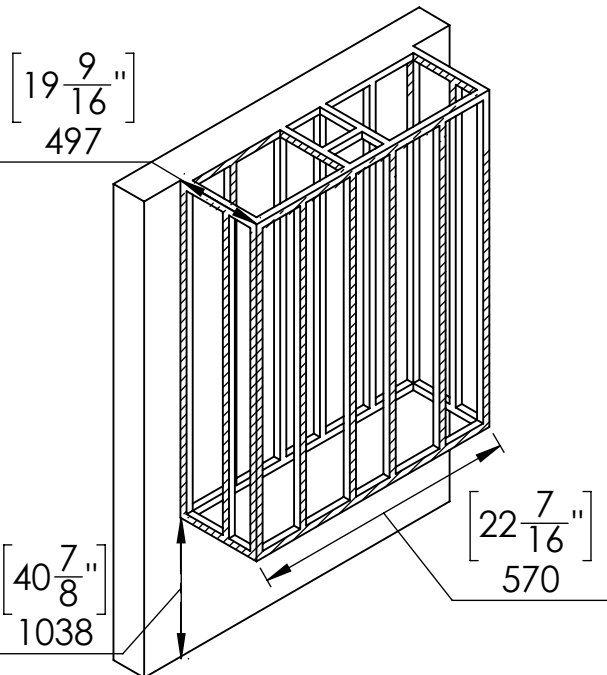

 Steel stud

Recess Installation

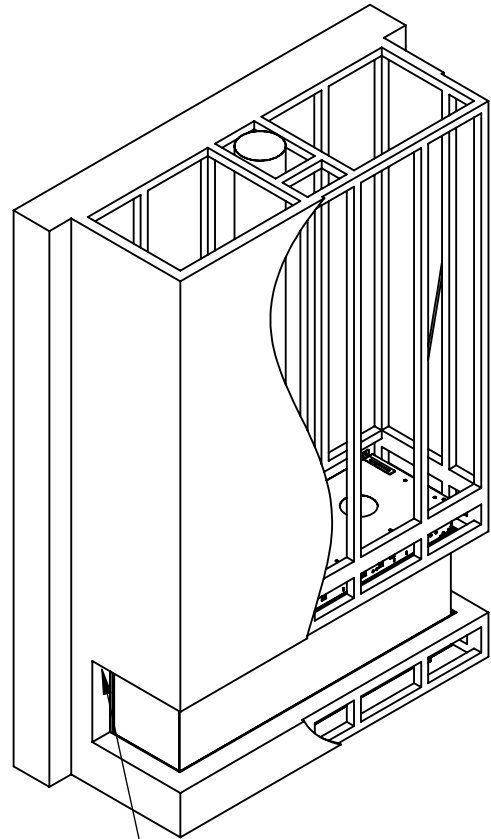

Top of Recess
4" max

Step 1 - Basic Framing :

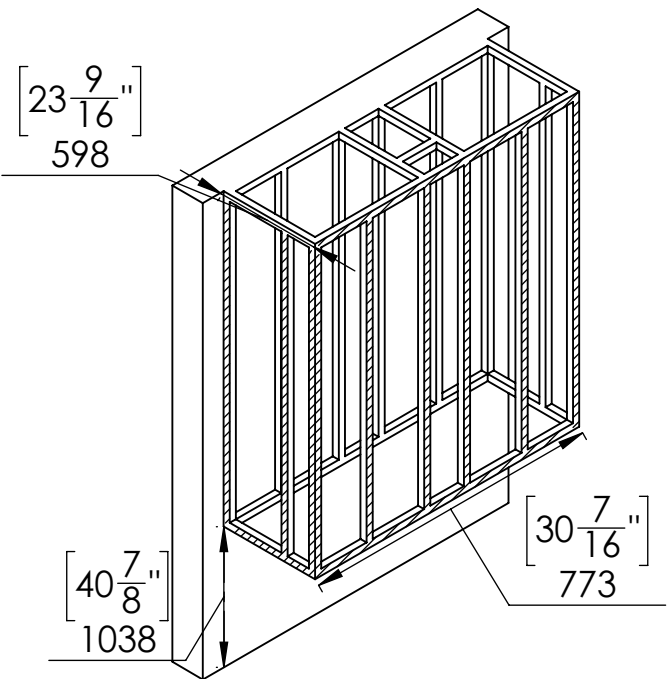

 Steel stud

Flat Installation

Step 2 -Positioning the Fireplace:

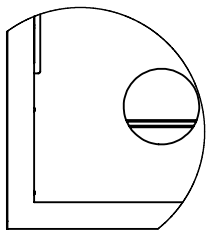
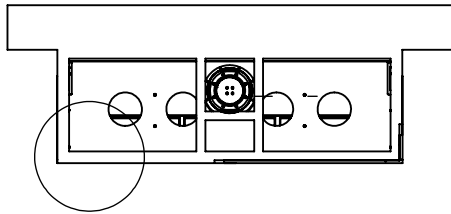

Fireplace frame finishing holder space to match wall finishing thickness

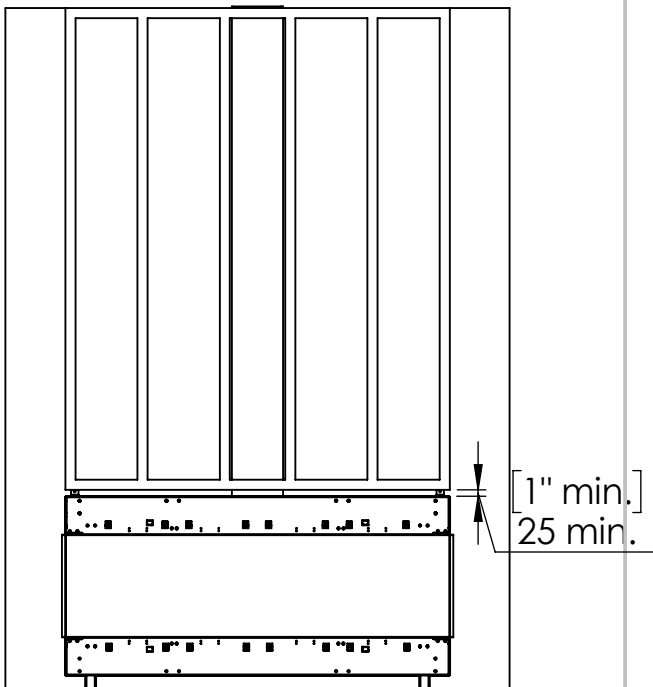

Recess Installation

Step 2 -Positioning the Fireplace:

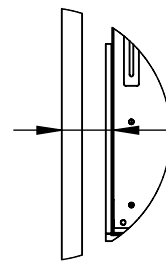
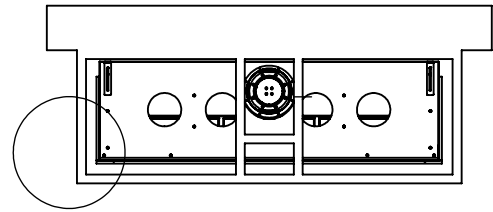

[4" max.]
102 max.

gap to match the max. length of top shelf.

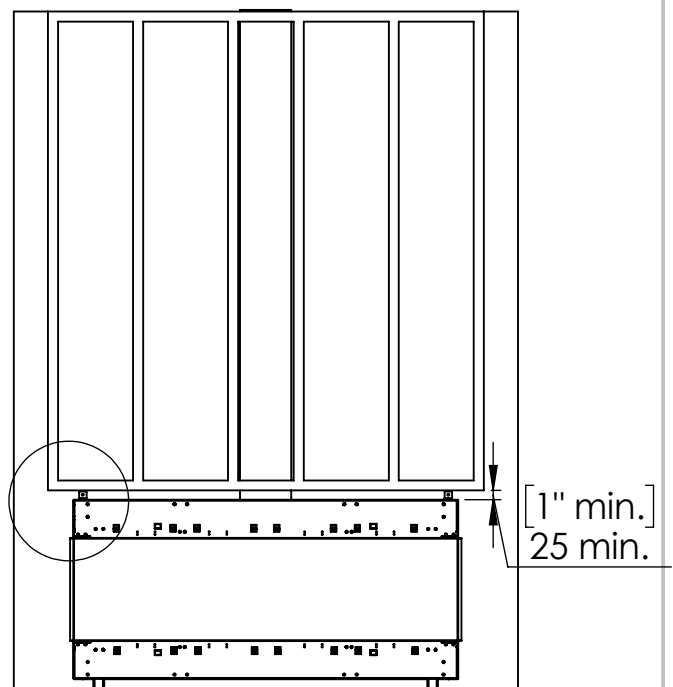

[4" max.]
102 max.

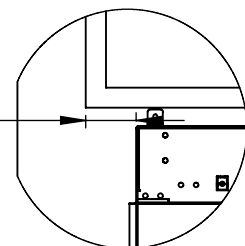

Flat Installation

Last Step - Finishing The Fireplace Wall:

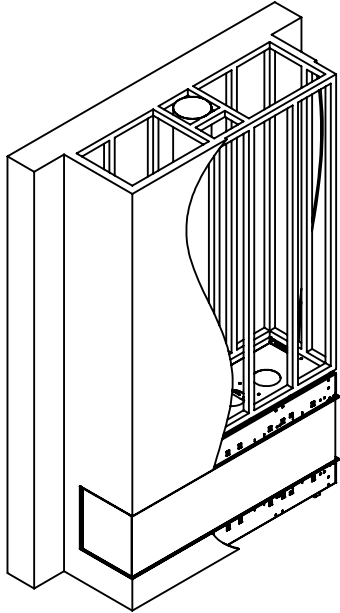

Recess Installation

Step 3 - Framing Front Studs For Recess
After positioning the Fireplace:

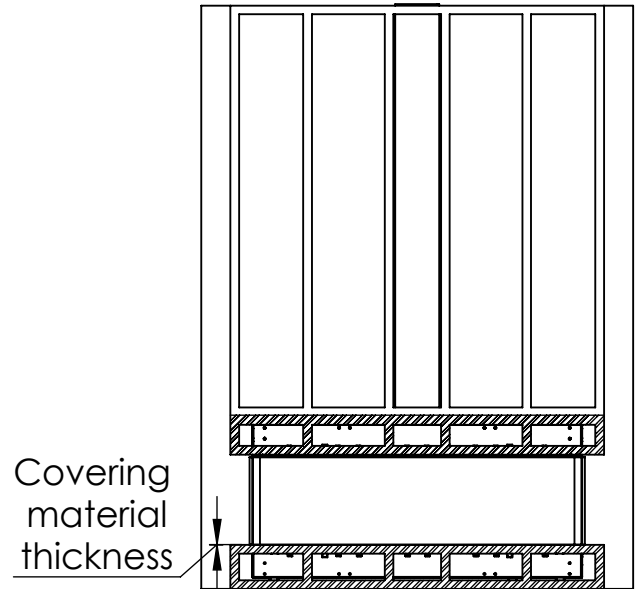

Last Step - Finishing The Fireplace Wall:

