

Factor	NG	LPG
Burner Type	105	105
Orifice	1200	320
BTU Max.	47000	35100
BTU min.	22750	18500
Kw/h	13.8k	10.2k
Chimney DIA.	5X8	5X8
Manifold Pressure[w.c]	4.9	10.4
Efficiency rate	78	82
Glass Size Length\Width	1270.5 X 423 mm	50" X 16" 9/16'
Appliance Weigh	145Kg	320lb

Appliance Location

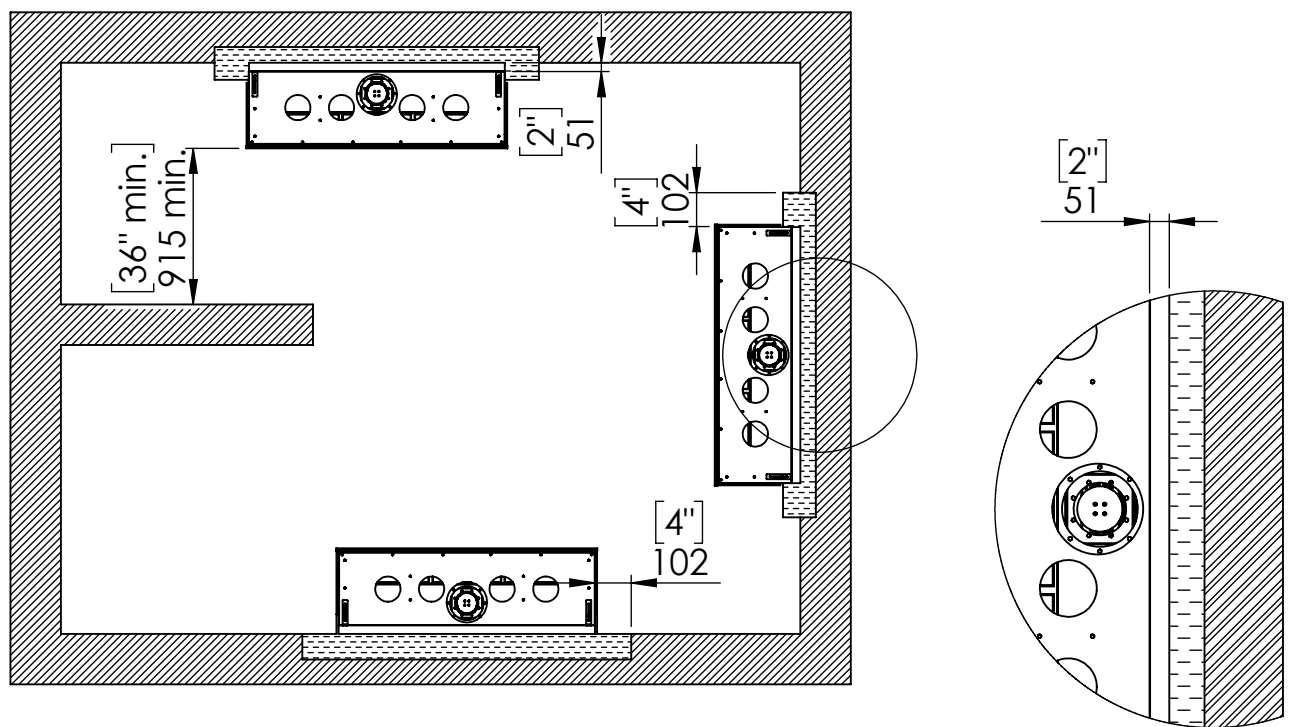

 Combustible Materials
 Non Combustible Materials



FLARE Double Corner 50

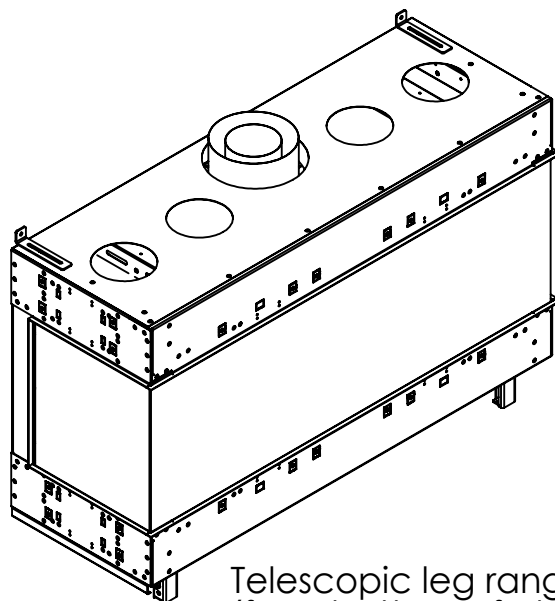
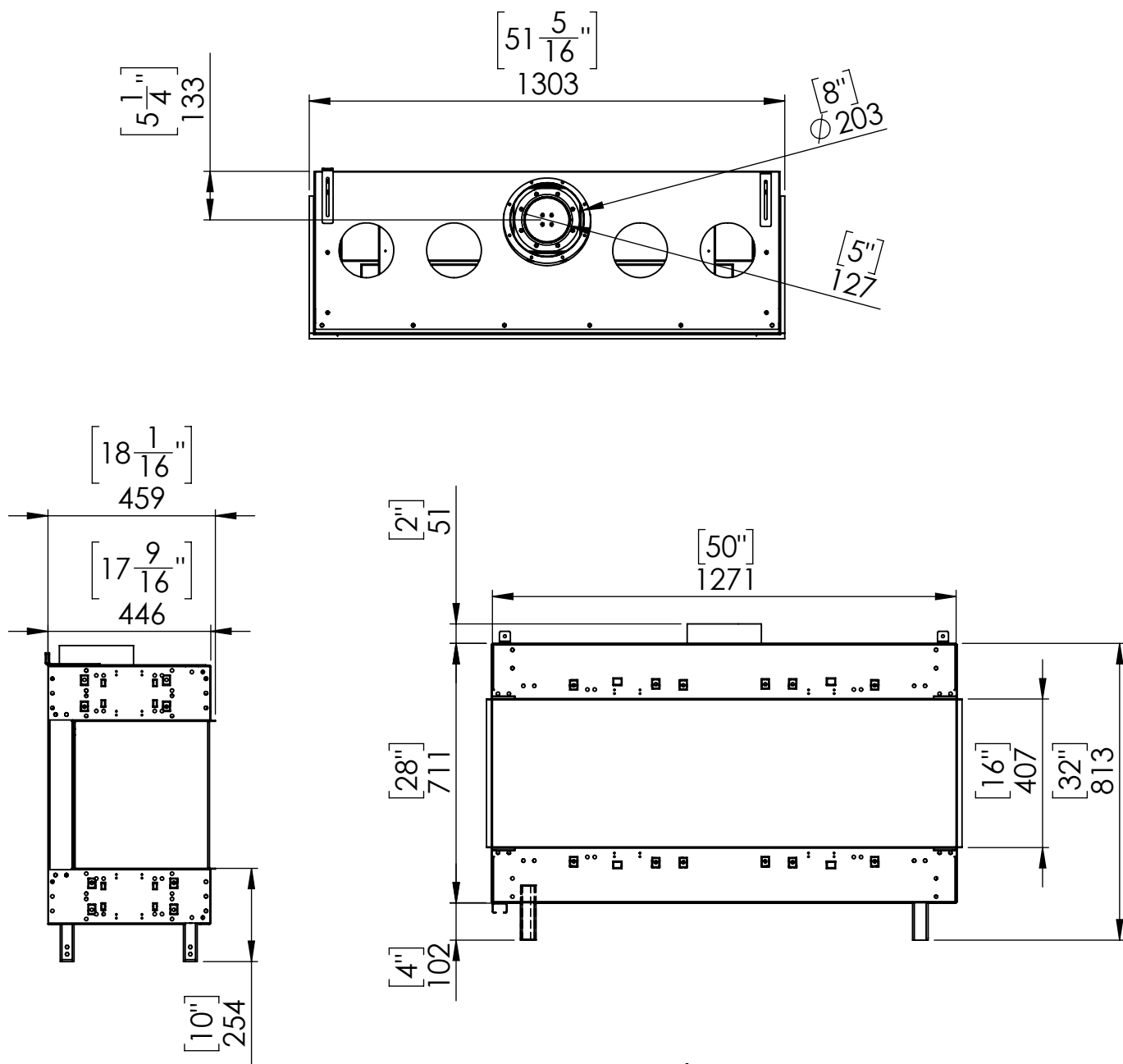

Telescopic leg ranges
(from bottom of glass): 10"-19"

Flat Installation

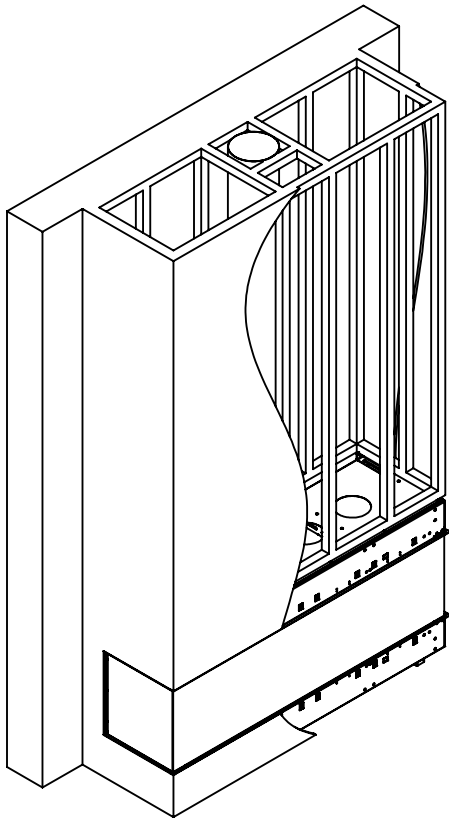

Step 1 - Basic Framing :

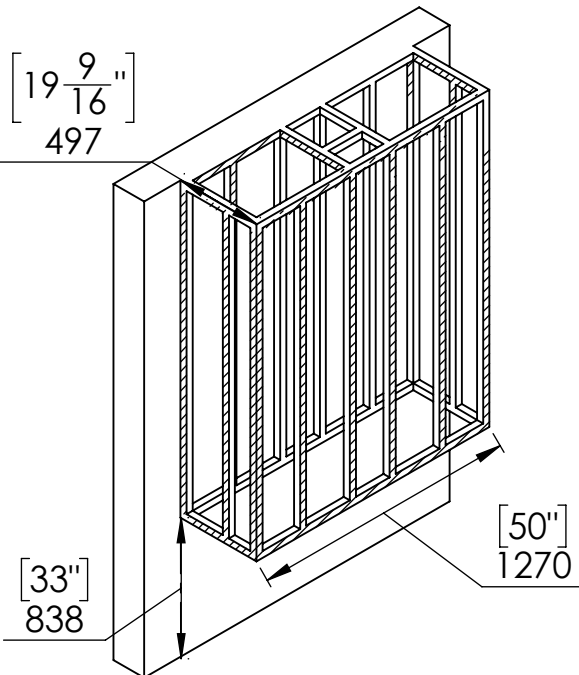

 Steel stud

Recess Installation

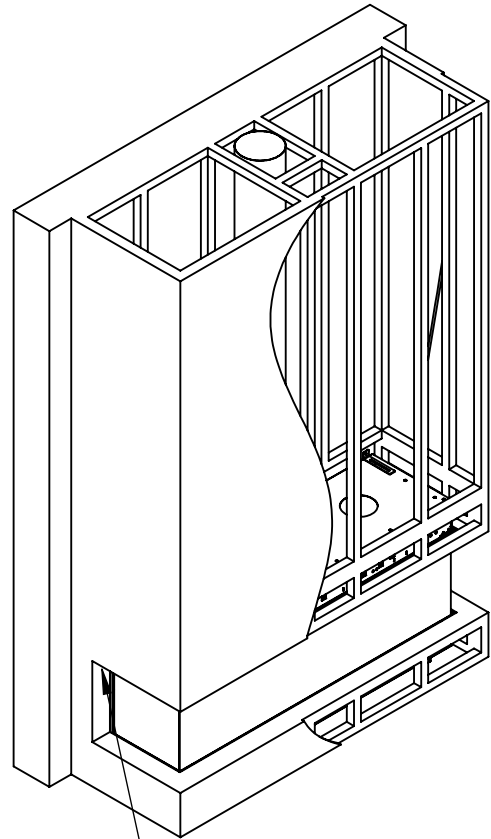

Top of Recess
4" max

Step 1 - Basic Framing :

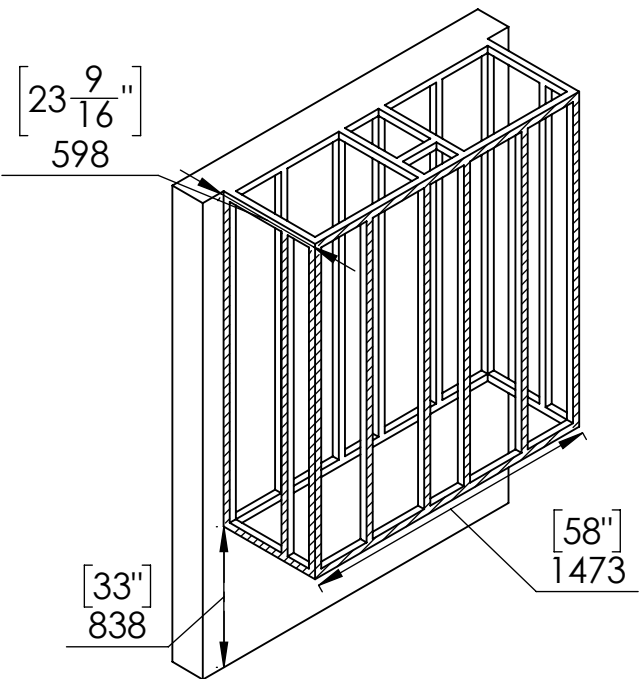

 Steel stud

Flat Installation

Step 2 -Positioning the Fireplace:

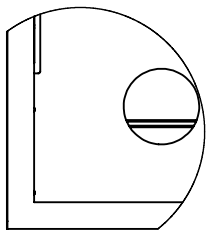
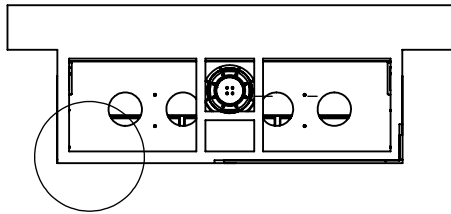

Fireplace frame finishing holder space to match wall finishing thickness

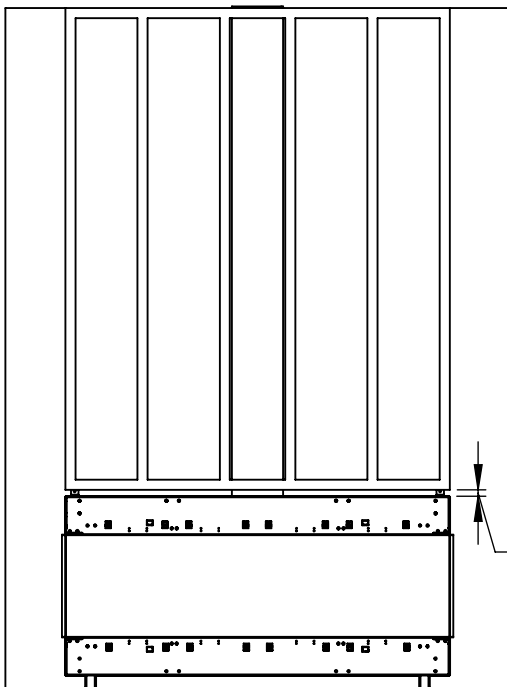

Recess Installation

Step 2 -Positioning the Fireplace:

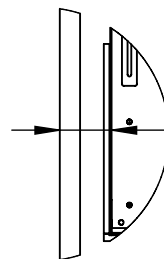
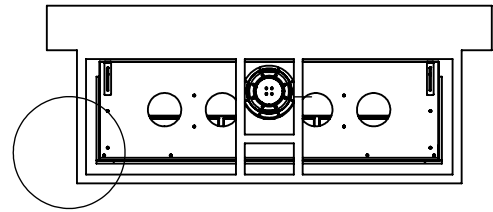

[4" max.]
102 max.

gap to match the max. length of top shelf.

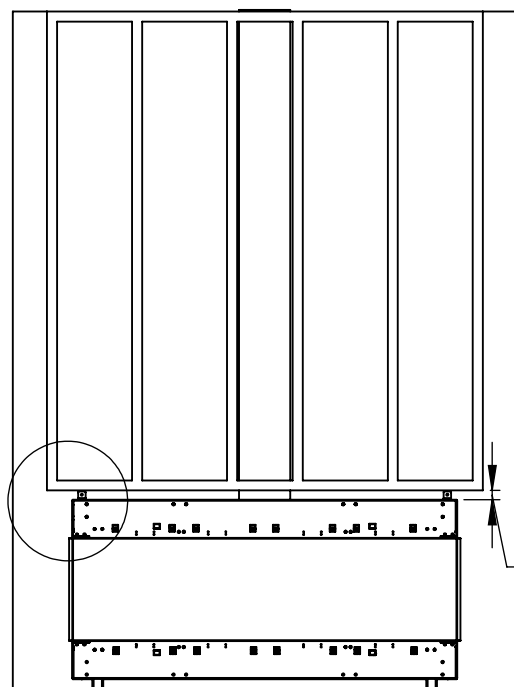

[4" max.]
102 max.

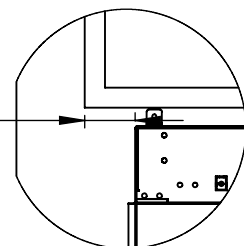

Flat Installation

Last Step - Finishing The Fireplace Wall:

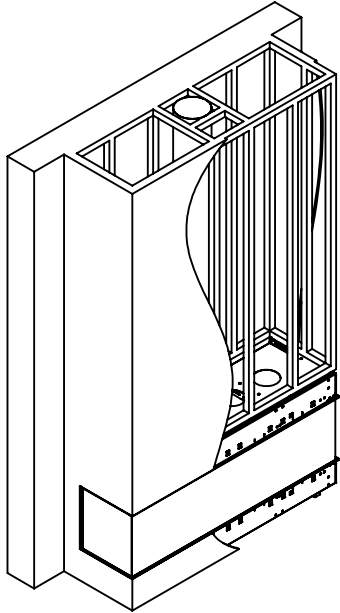

Recess Installation

Step 3 - Framing Front Studs For Recess
After positioning the Fireplace:

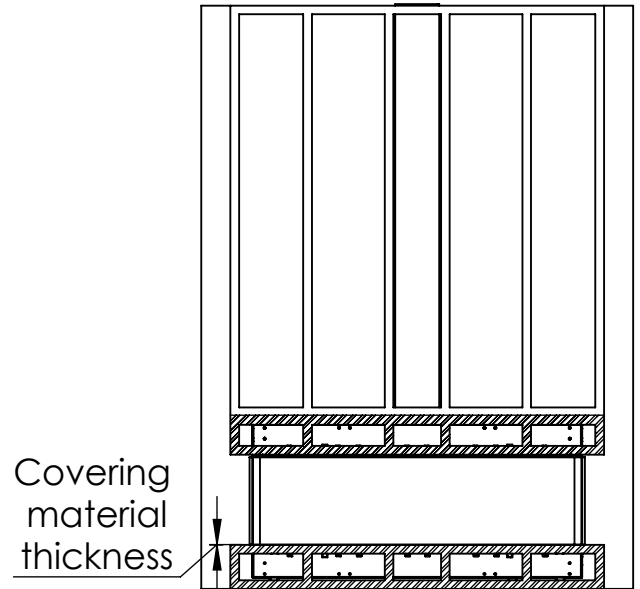

Last Step - Finishing The Fireplace Wall:

