

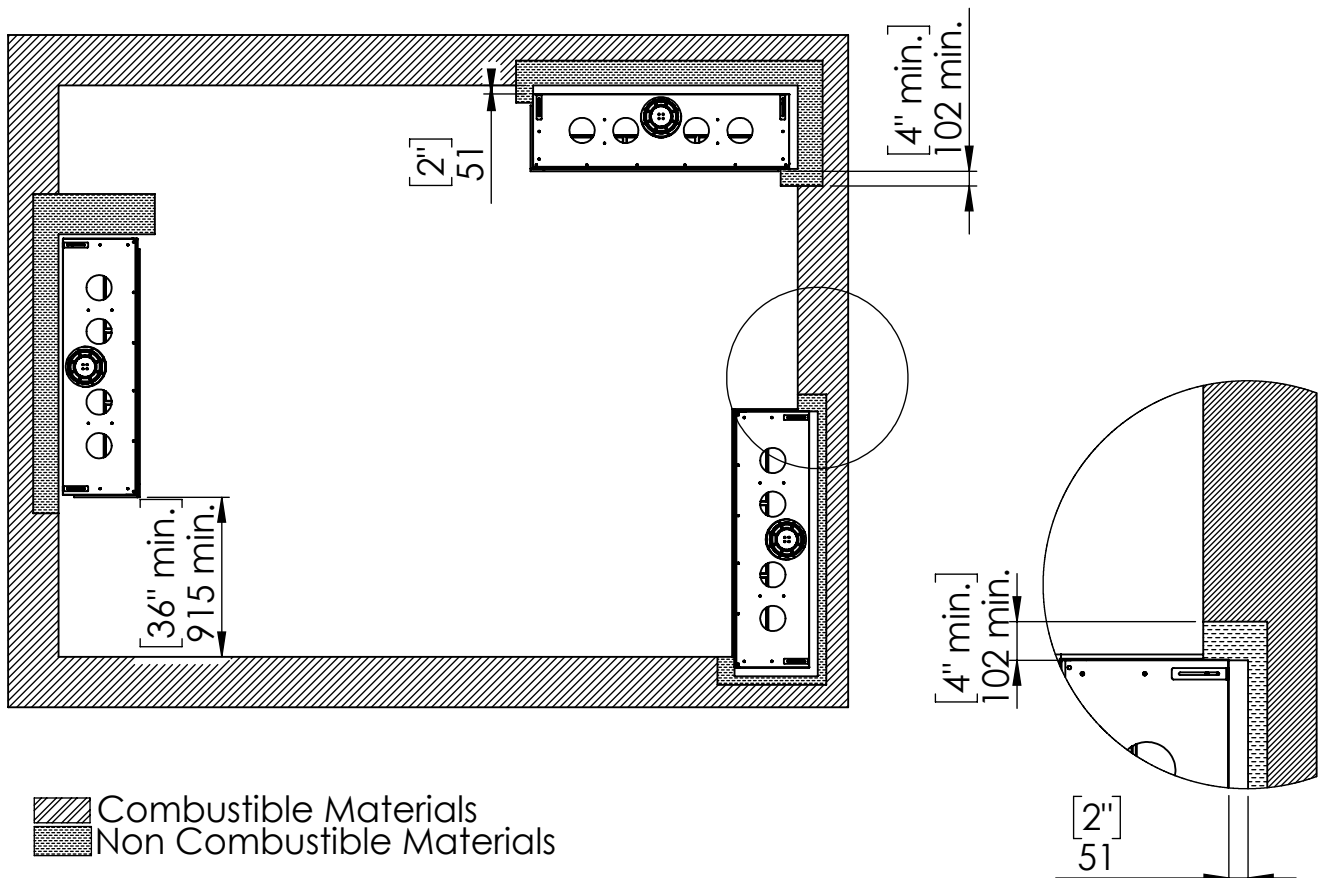

# Specifications for Appliance Flare Left Corner 30

Factor	NG	LPG
Burner Type	55	55
Orifice	650	260
BTU Max.	34000	18500
BTU min.	26200	16000
Kw/h	10k	7.7k
Chimney DIA.	4X6	4X6
Manifold Pressure[w.c]	6.4	10.6
Efficiency rate	79	81
Glass Size Length\Width	770.5 X 620 mm	30 5/16" X 24 7/16"
Appliance Weigh	100Kg	220lb

## Appliance Location



# FLARE Left Corner 30

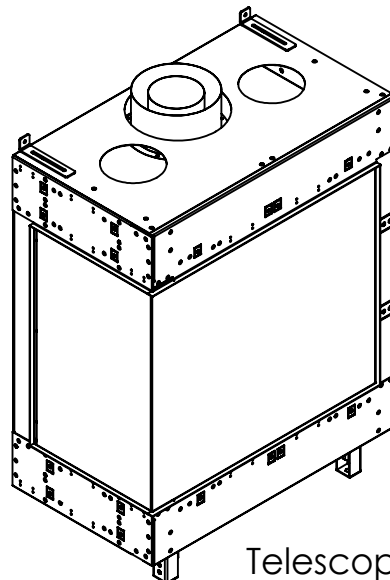
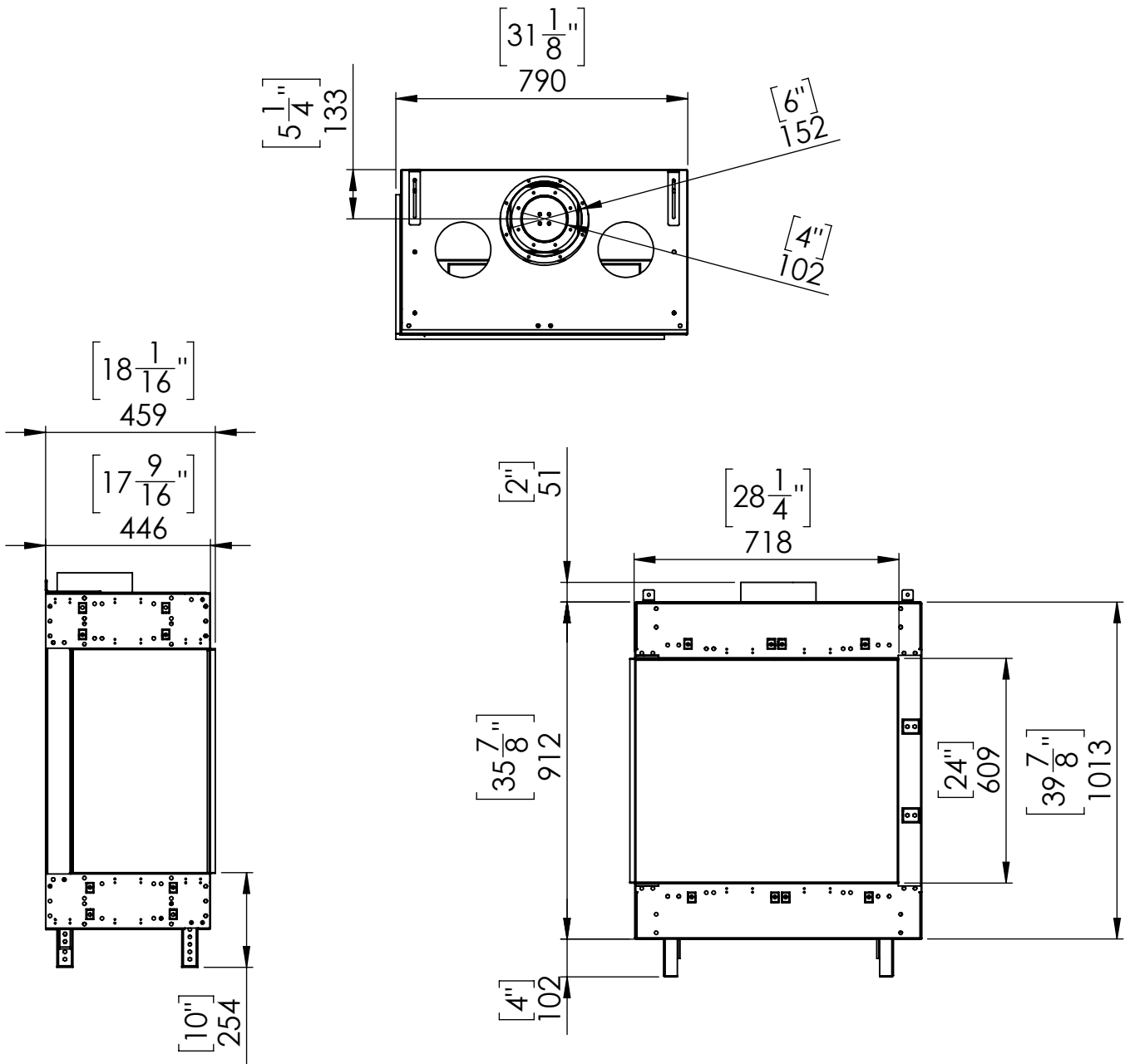

Telescopic leg ranges  
(from bottom of glass): 10"-19"

## Flat Installation

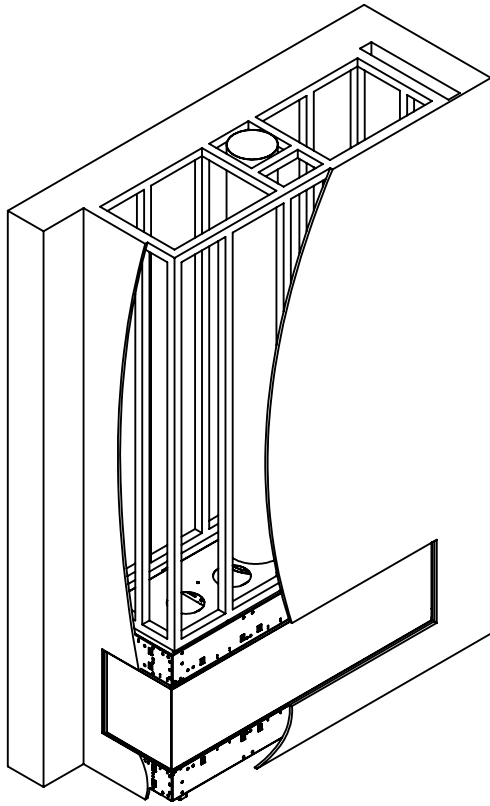

Step 1 - Basic Framing :

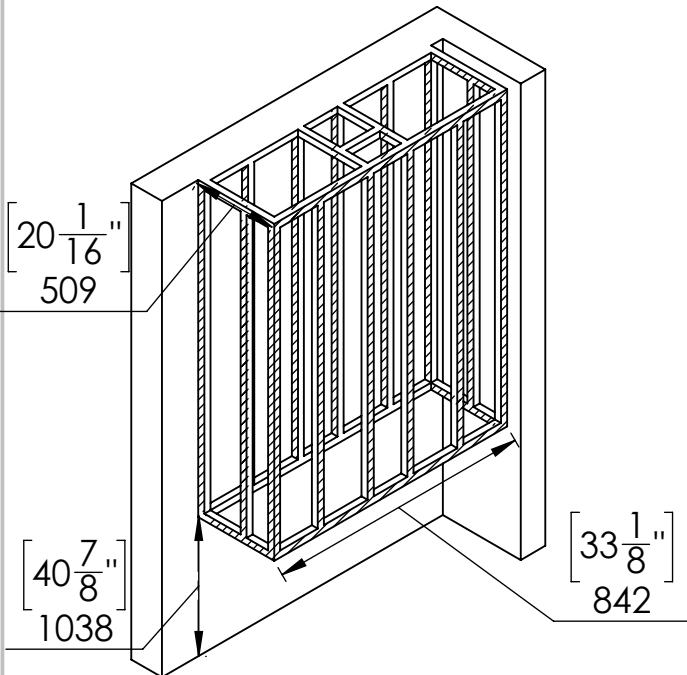

 Metal Studs

## Recess Installation

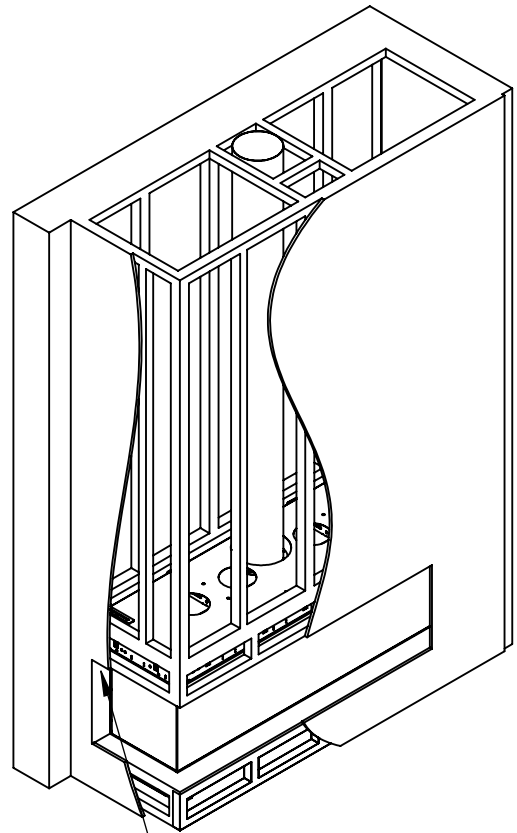

Top of Recess  
4" max

Step 1 - Basic Framing :

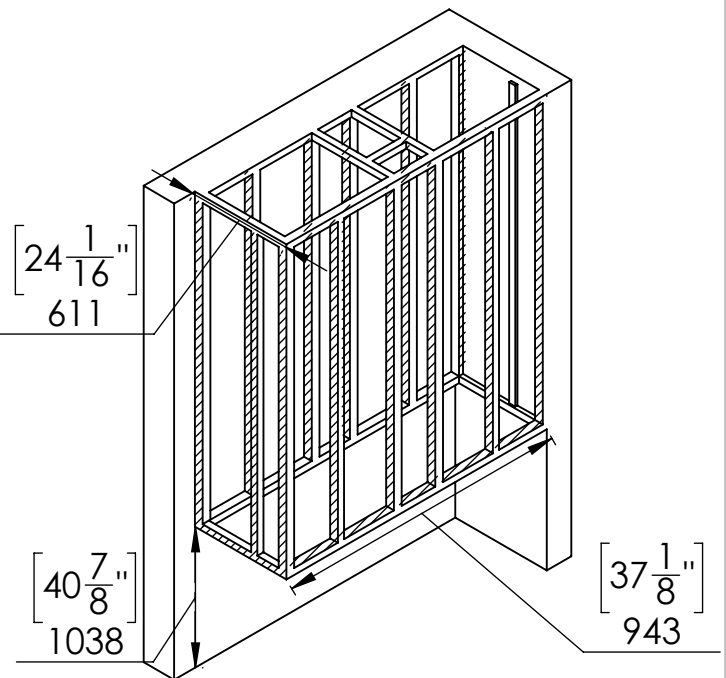

 Metal Studs

## Flat Installation

Step 2 -Positioning the Fireplace:

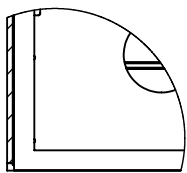
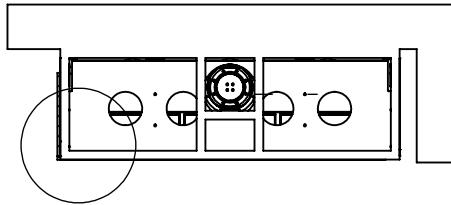

Fireplace frame finishing holder space to match wall finishing thickness

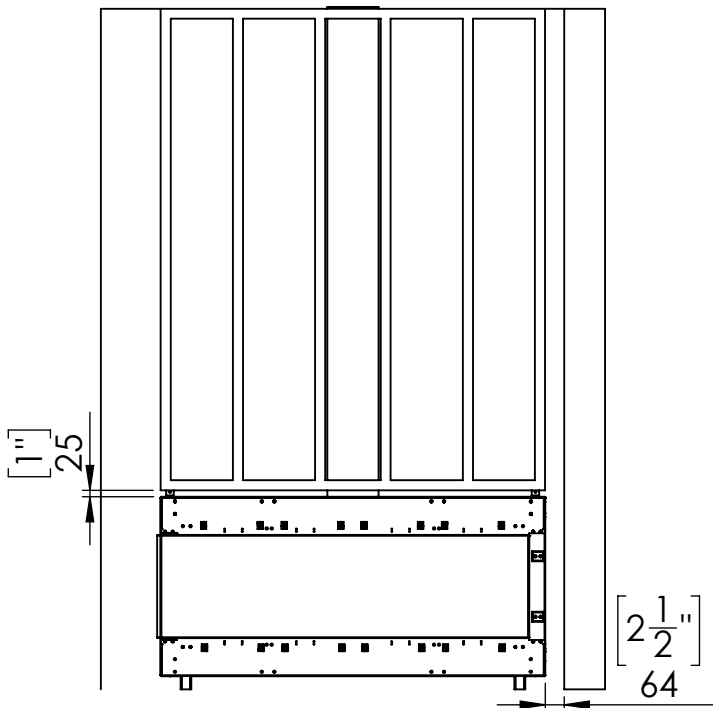

## Recess Installation

Step 2 -Positioning the Fireplace:

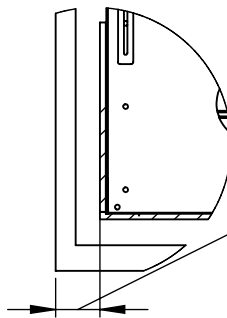
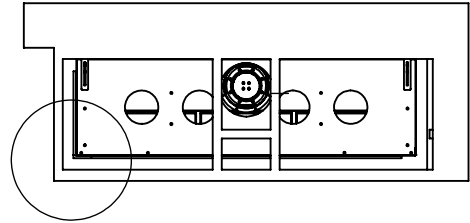

[4"]  
102 gap to match the max. length of top shelf.

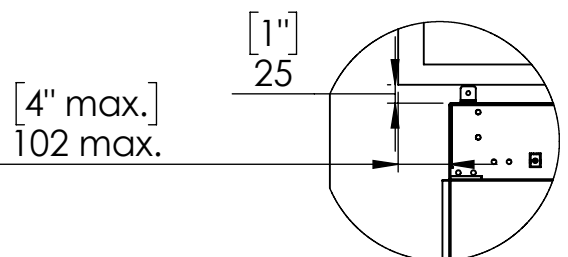
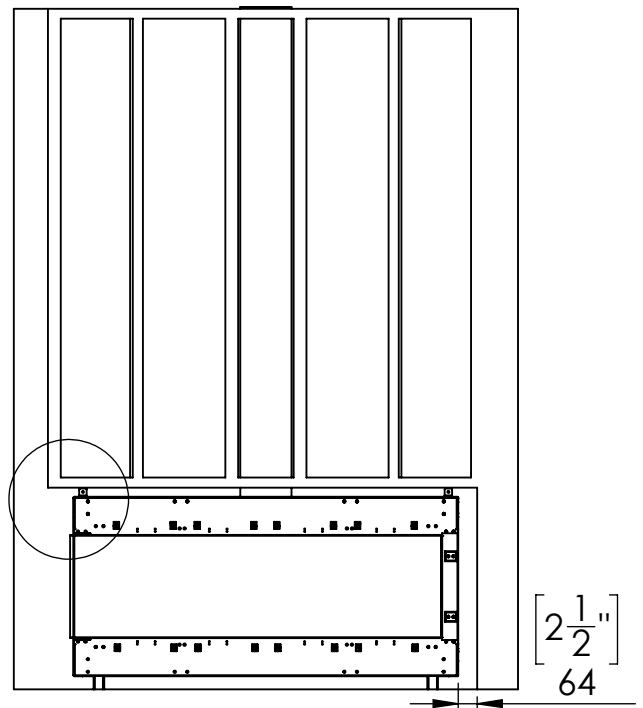

## Flat Installation

Last Step - Finishing The Fireplace Wall:

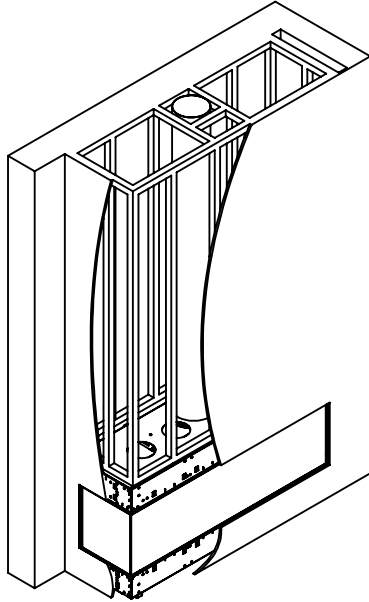

## Recess Installation

Step 3 - Framing Front Studs For Recess  
After positioning the Fireplace:

Covering  
material  
thickness

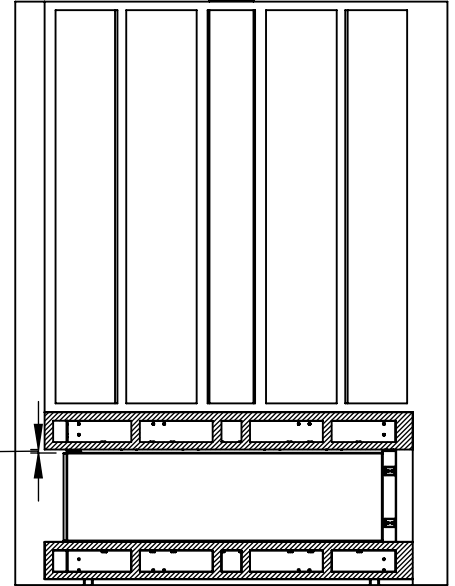

Last Step - Finishing The Fireplace Wall:

