

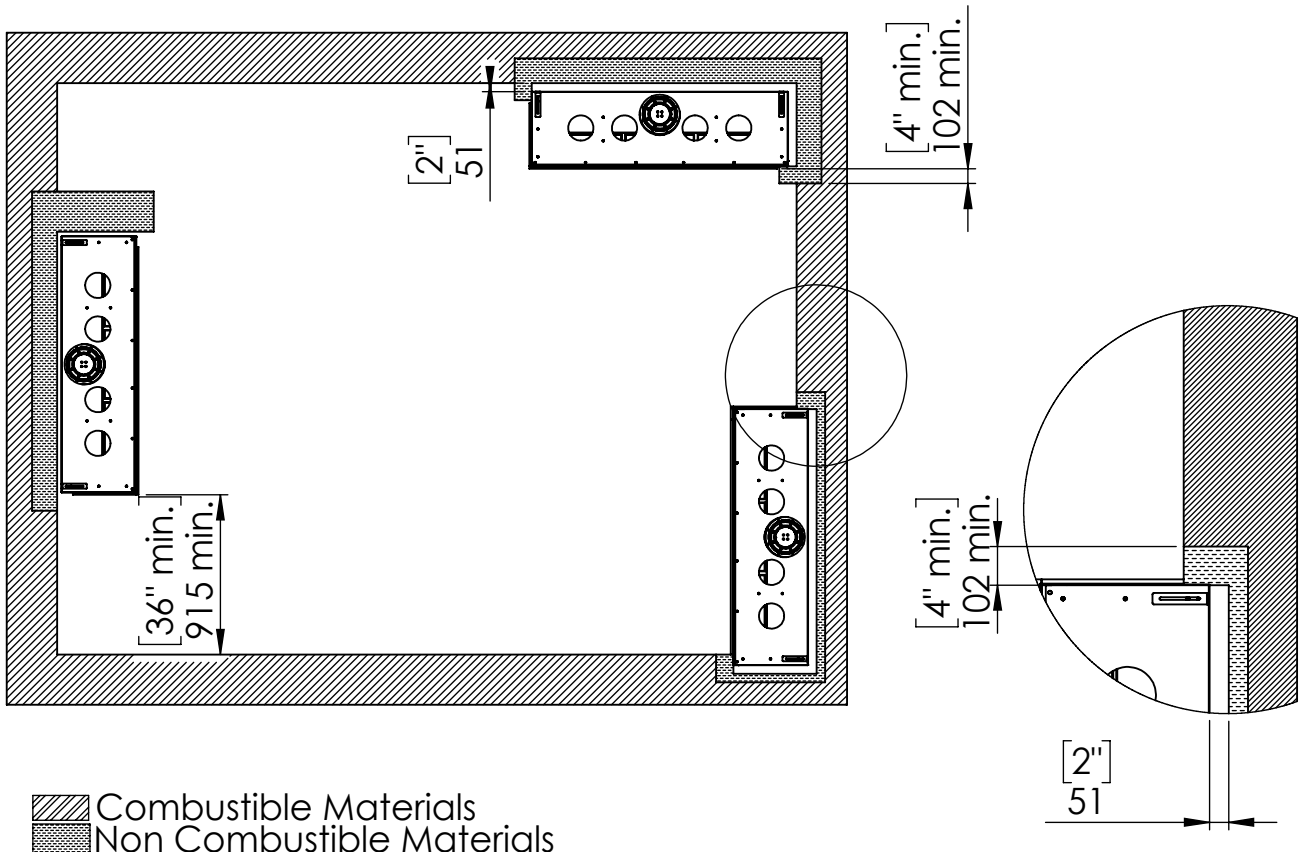

Specifications for Appliance Flare Left Corner 50H

Factor	NG	LPG
Burner Type	105	105
Orifice	1200	320
BTU Max.	47000	35100
BTU min.	22750	18500
Kw/h	13.8k	10.2k
Chimney DIA.	5X8	5X8
Manifold Pressure[w.c]	4.9	10.4
Efficiency rate	78	82
Glass Size Length\Width	1270.5 X 620 mm	50" X 24" 7/16'
Appliance Weigh	155Kg	340lb

Appliance Location



FLARE Left Corner 50H

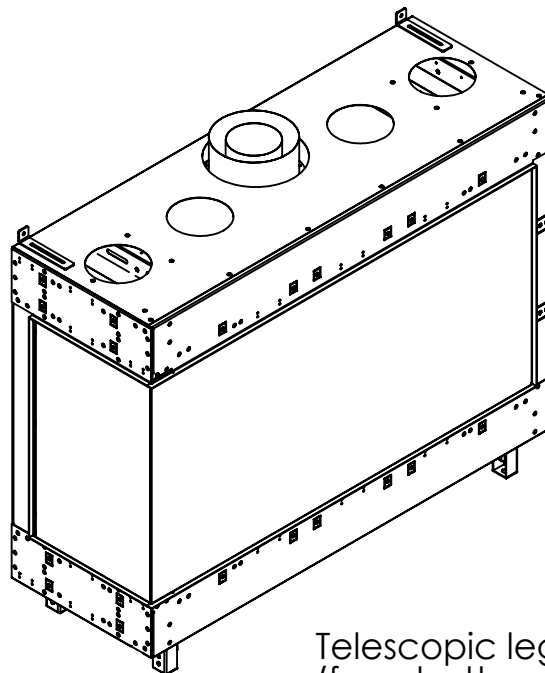
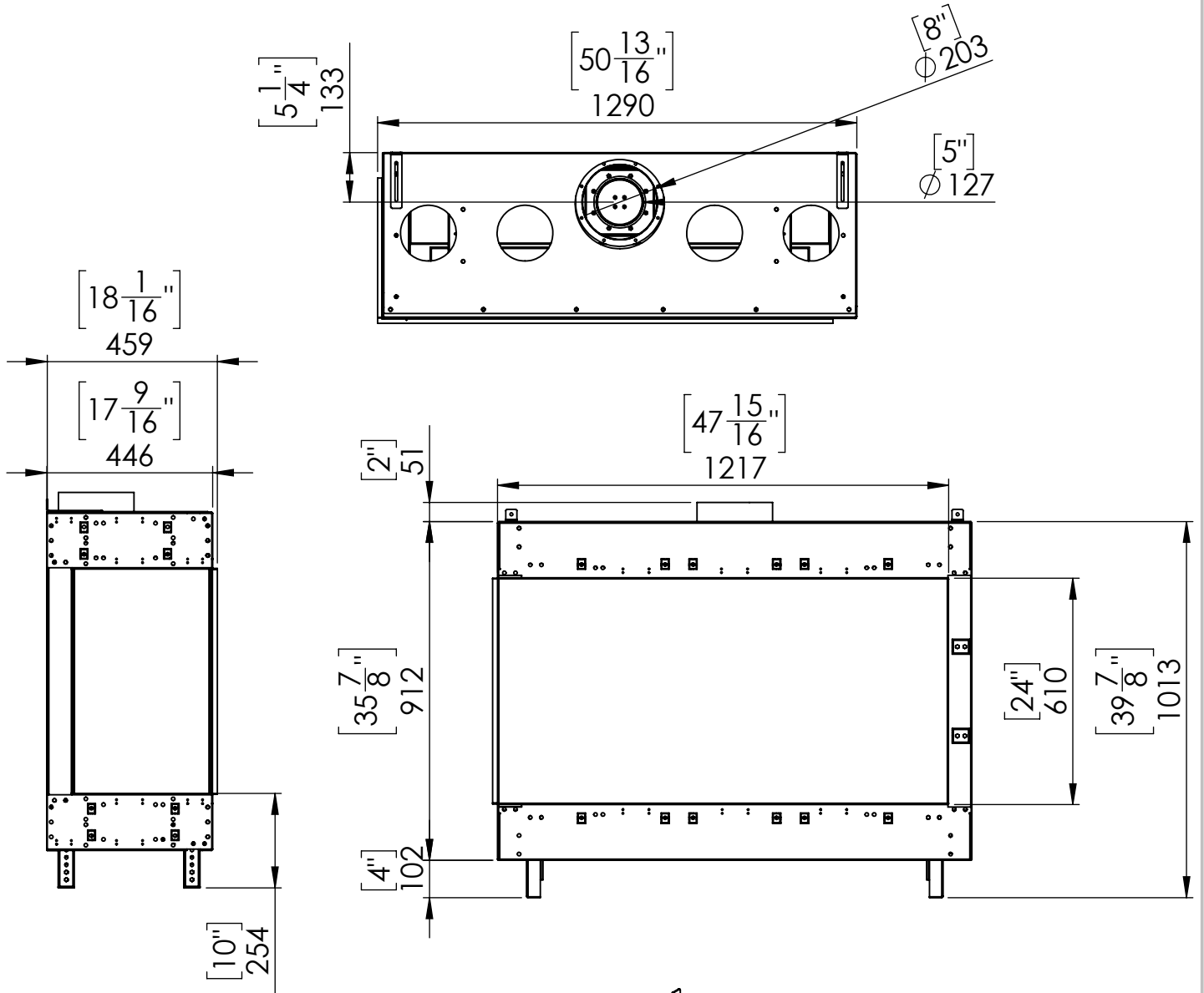

Telescopic leg ranges
(from bottom of glass): 10"-19"

Flat Installation

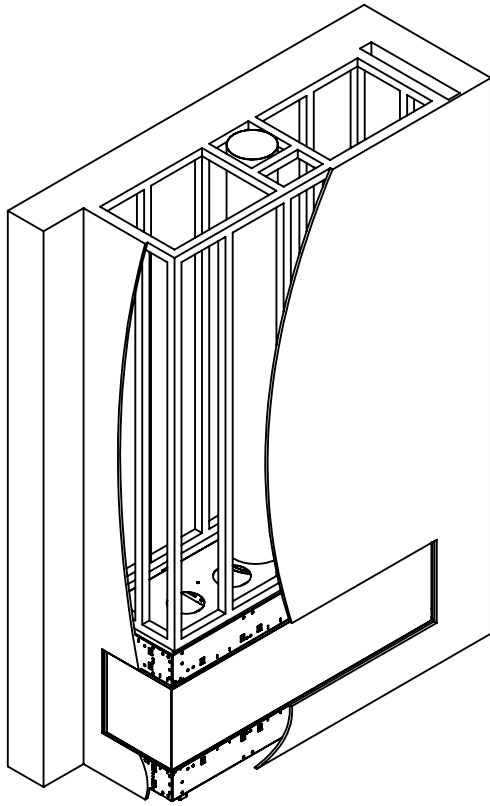

Step 1 - Basic Framing :

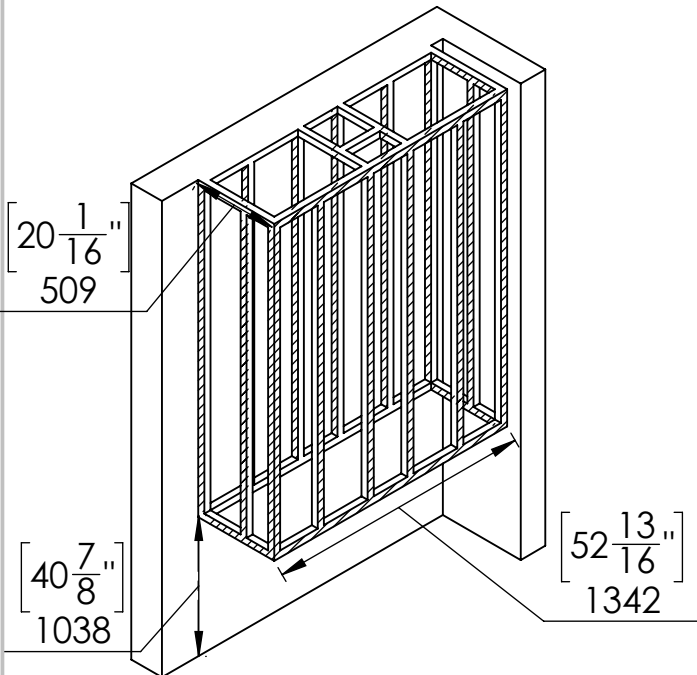

 Metal Studs

Recess Installation

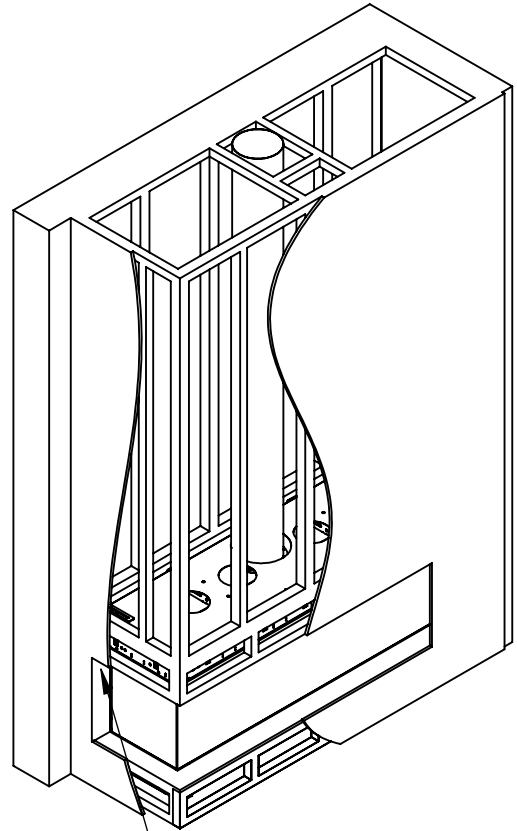

Top of Recess
4" max

Step 1 - Basic Framing :

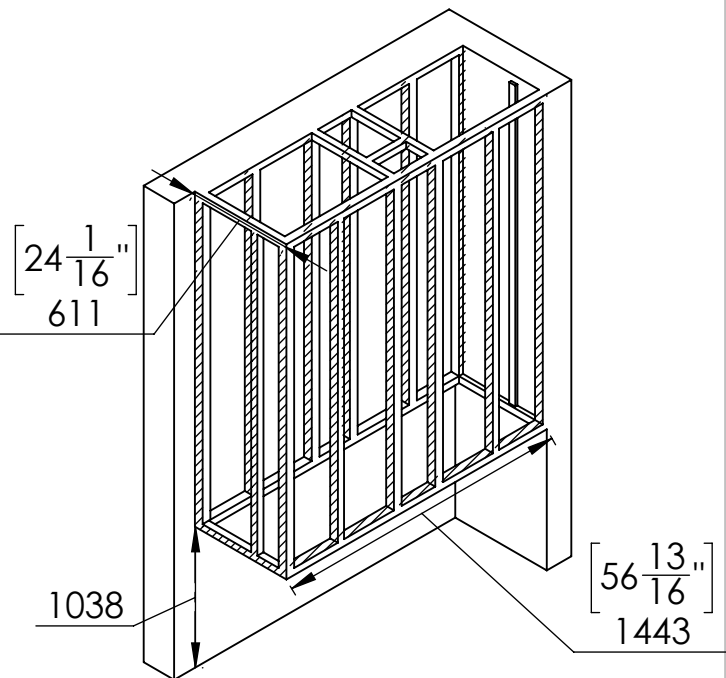

 Metal Studs

Flat Installation

Step 2 -Positioning the Fireplace:

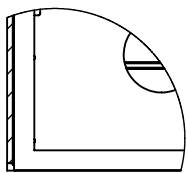
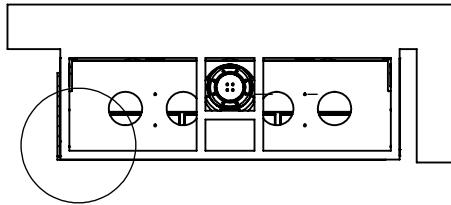

Fireplace frame finishing holder space to match wall finishing thickness

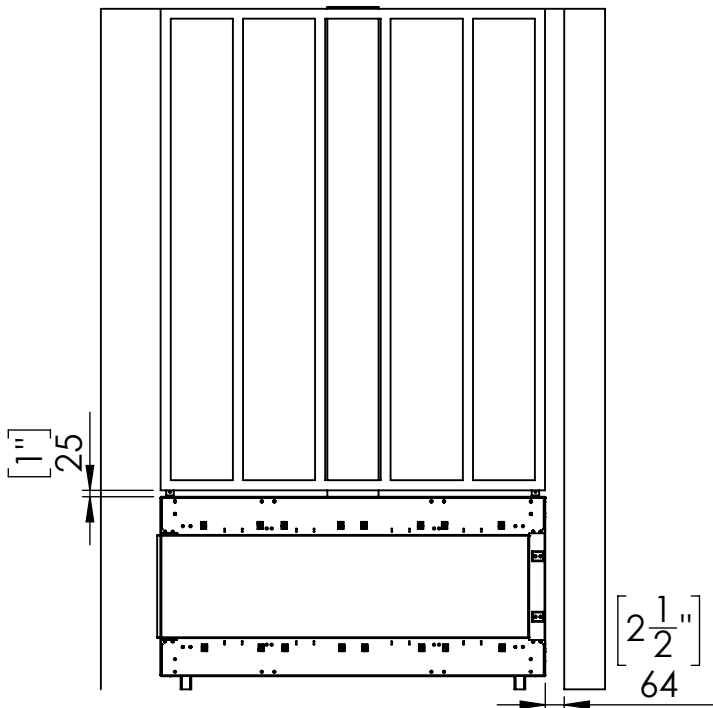

Recess Installation

Step 2 -Positioning the Fireplace:

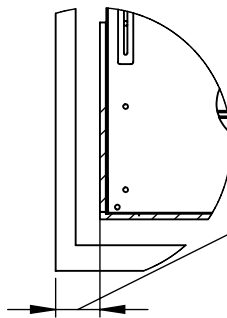
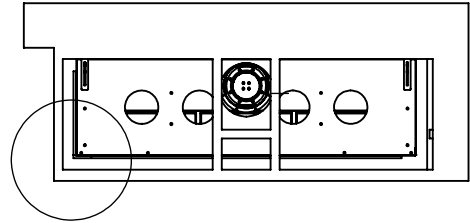

[4"]
102 gap to match the max. length of top shelf.

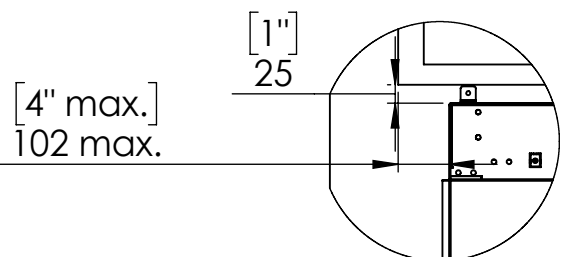
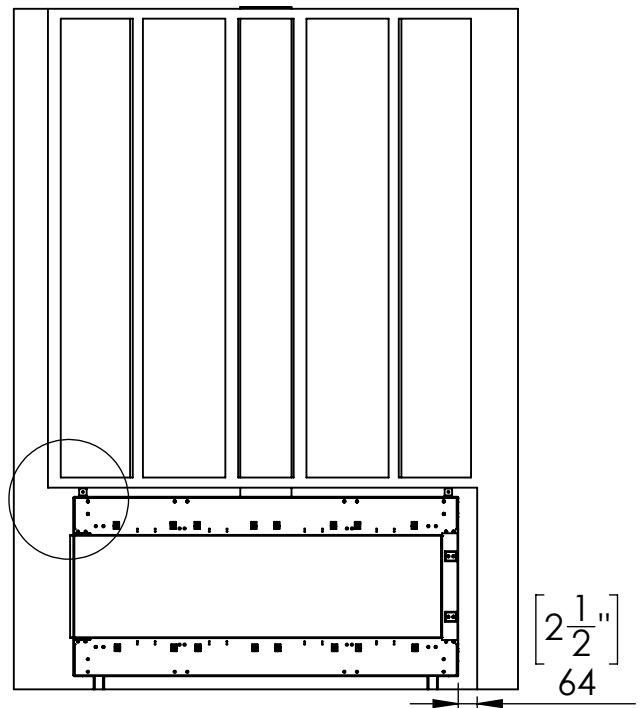

Flat Installation

Last Step - Finishing The Fireplace Wall:

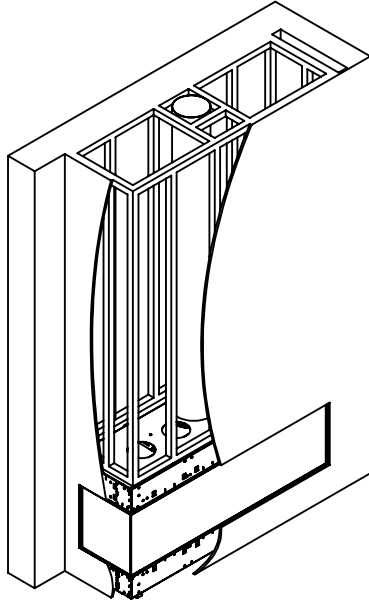

Recess Installation

Step 3 - Framing Front Studs For Recess
After positioning the Fireplace:

Covering
material
thickness

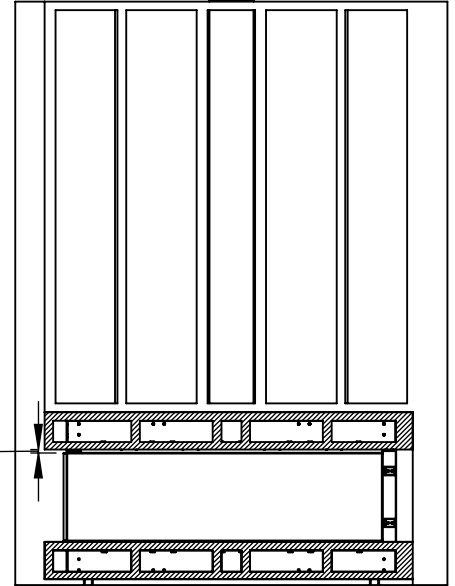

Last Step - Finishing The Fireplace Wall:

