

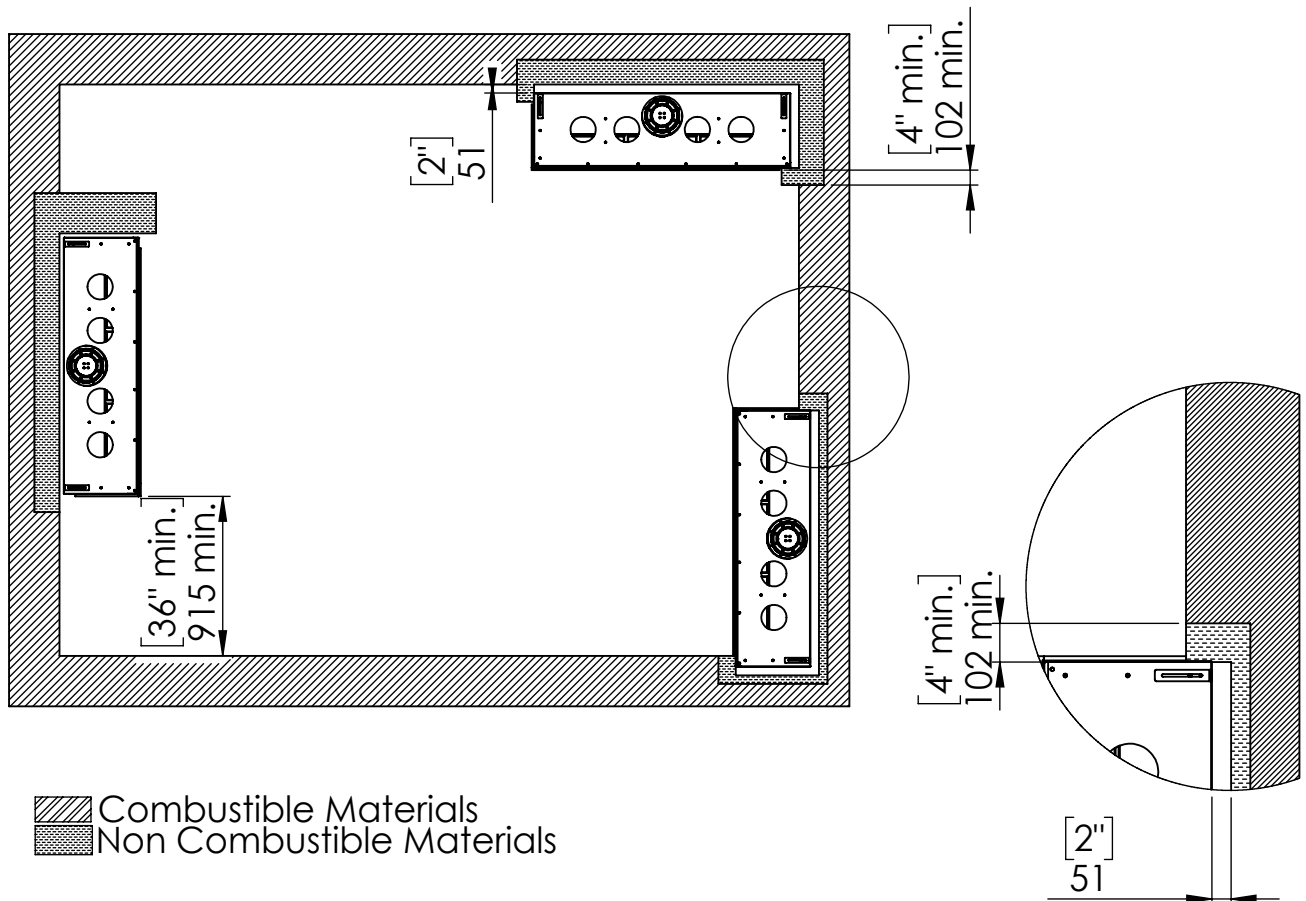

Specifications for Appliance Flare Left Corner 60H

Factor	NG	LPG
Burner Type	35,55,35	35,55,35
Orifice	500,800,500	160,160,160
BTU Max.	50000	41000
BTU min.	28000	20000
Kw/h	14.6k	12k
Chimney DIA.	5X8	5X8
Manifold Pressure[w.c]	3.3	10.4
Efficiency rate	77	80
Glass Size Length\Width	1520.5 X620 mm	59" 7/8' X 24" 7/16'
Appliance Weigh	180Kg	395lb

Appliance Location



FLARE Left Corner 60H

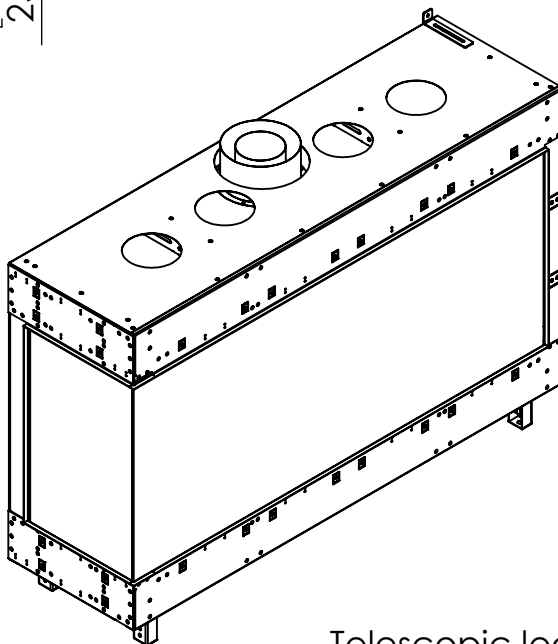
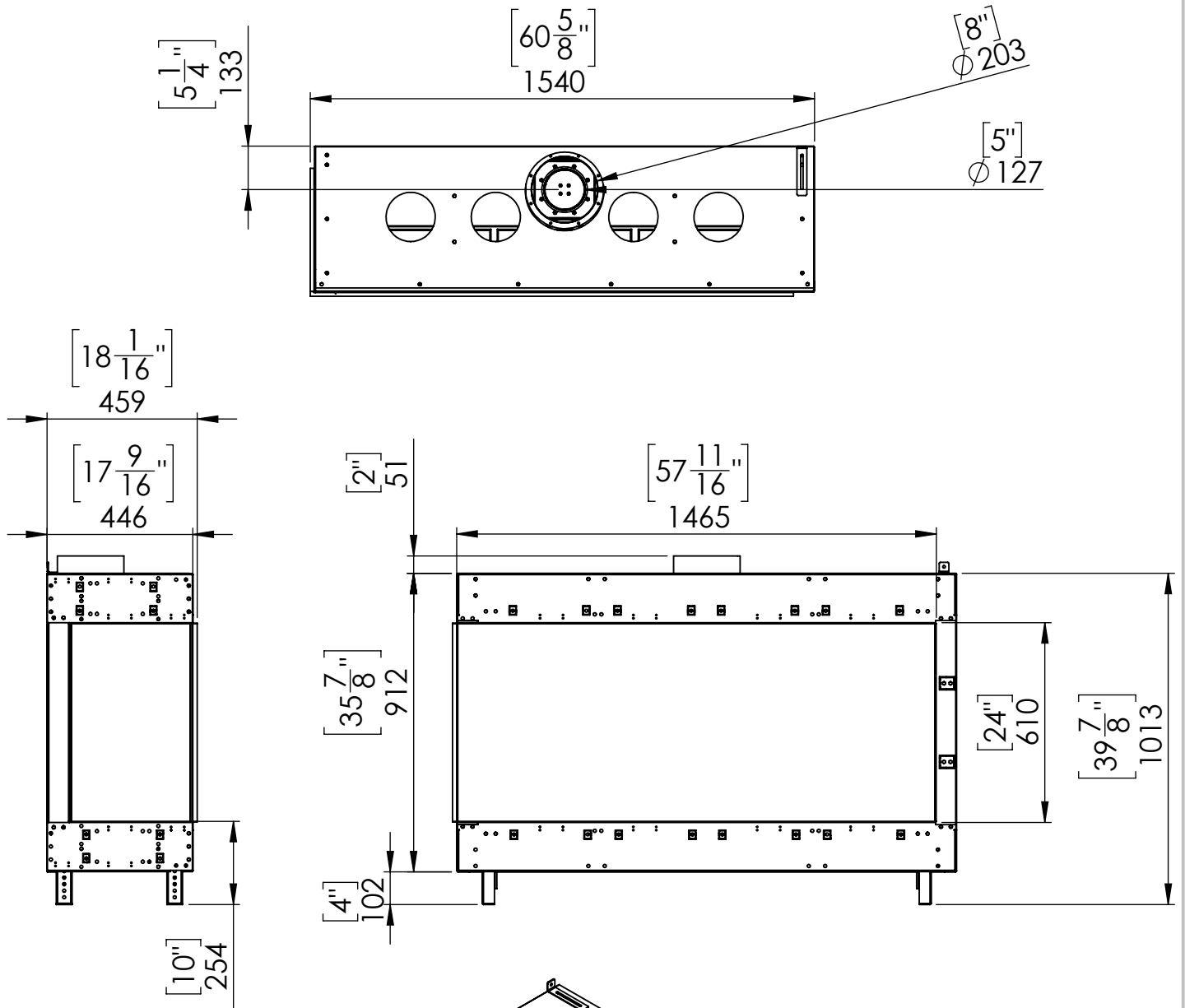

Telescopic leg ranges
(from bottom of glass): 10"-19"

Flat Installation

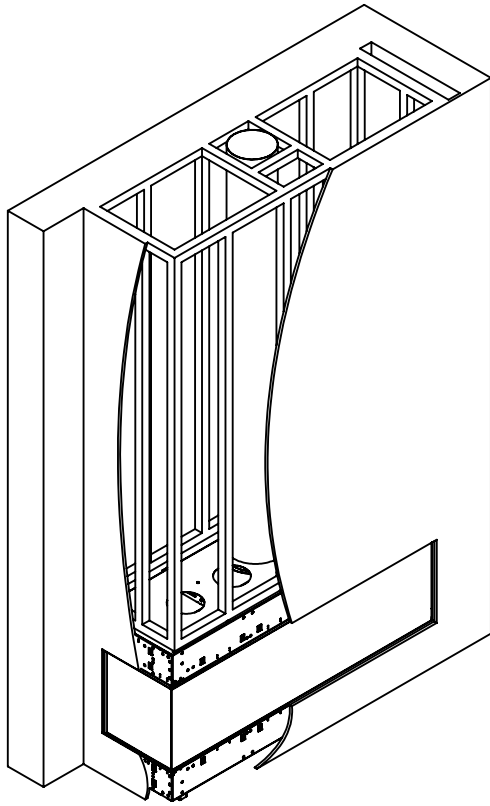

Step 1 - Basic Framing :

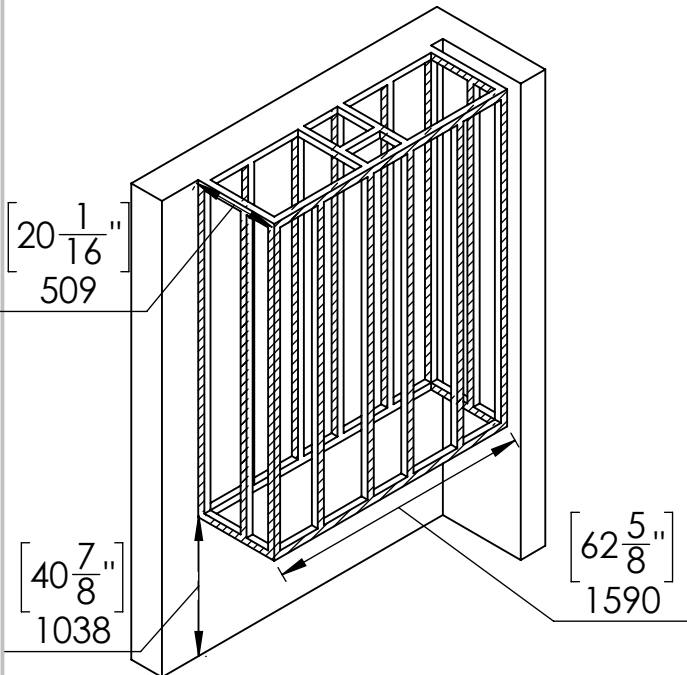

 Metal Studs

Recess Installation

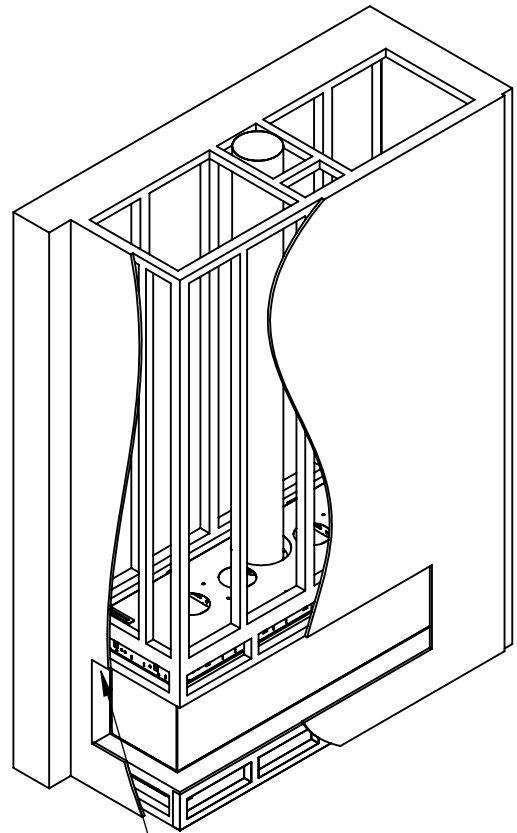

Top of Recess
4" max

Step 1 - Basic Framing :

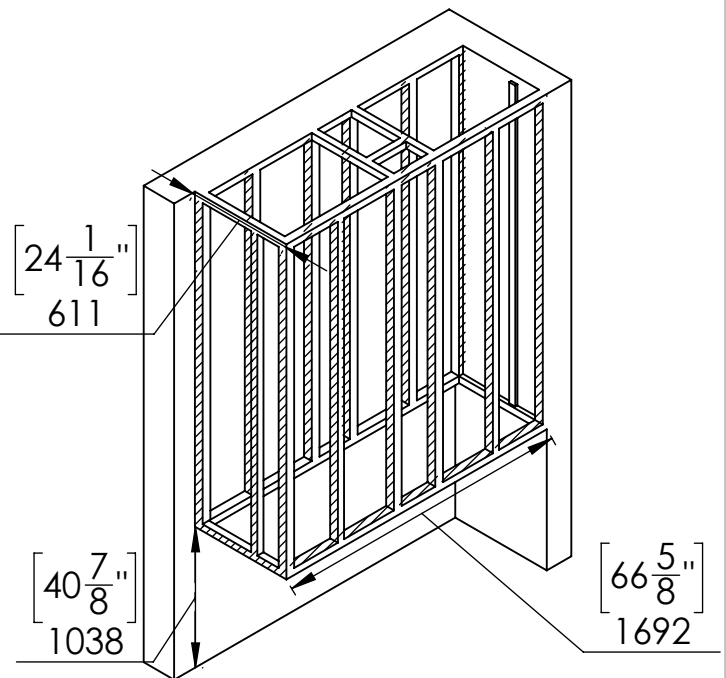

 Metal Studs

Flat Installation

Step 2 -Positioning the Fireplace:

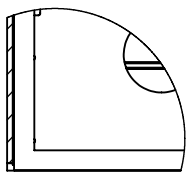
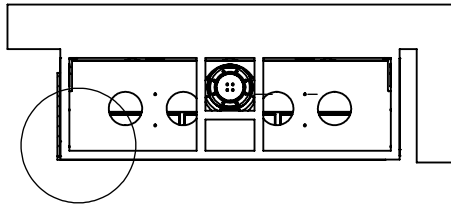

Fireplace frame finishing holder space to match wall finishing thickness

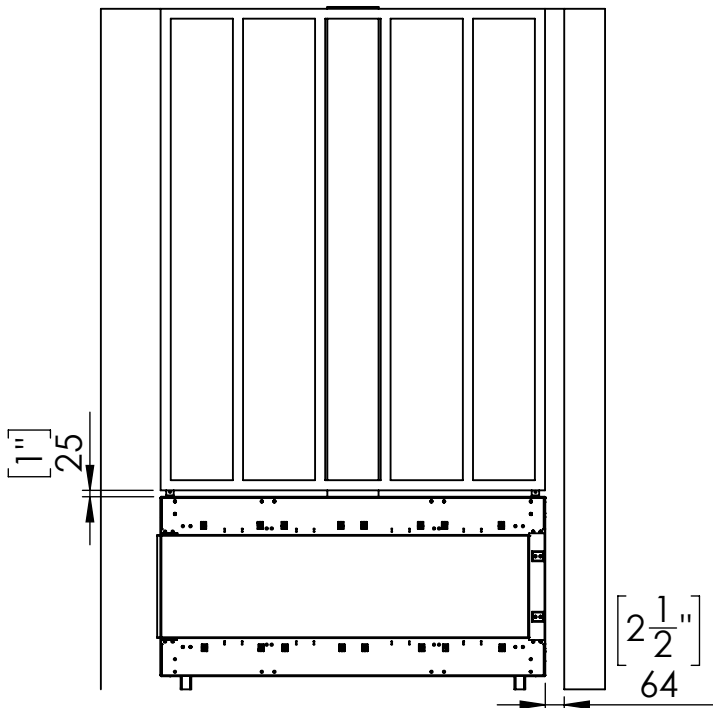

Recess Installation

Step 2 -Positioning the Fireplace:

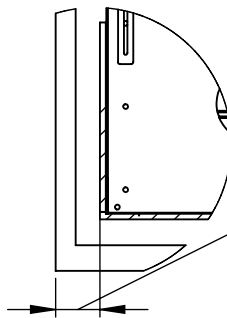
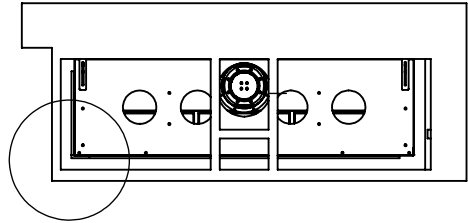

[4"]
102

gap to match the max. length of top shelf.

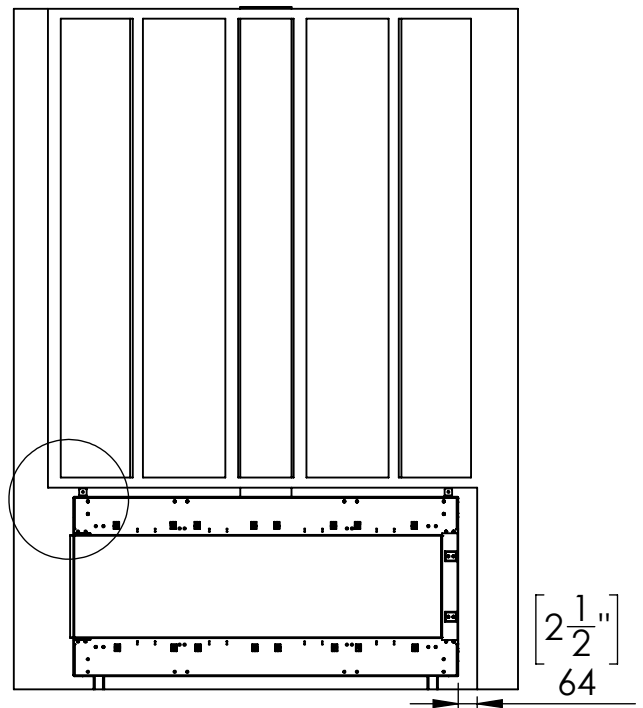

[4" max.]
102 max.

[1"]
25

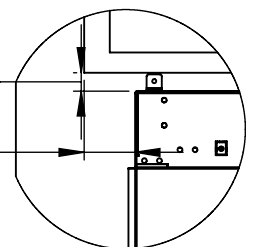

Flat Installation

Last Step - Finishing The Fireplace Wall:

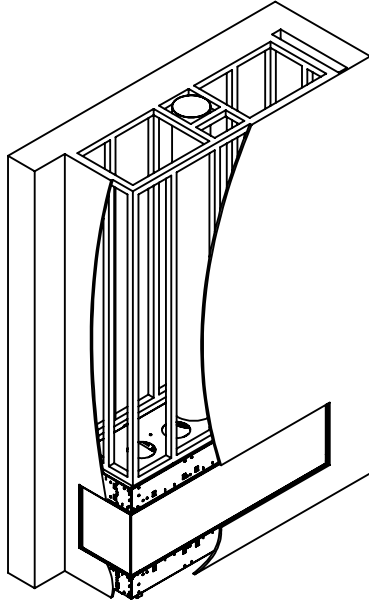

Recess Installation

Step 3 - Framing Front Studs For Recess
After positioning the Fireplace:

Covering
material
thickness

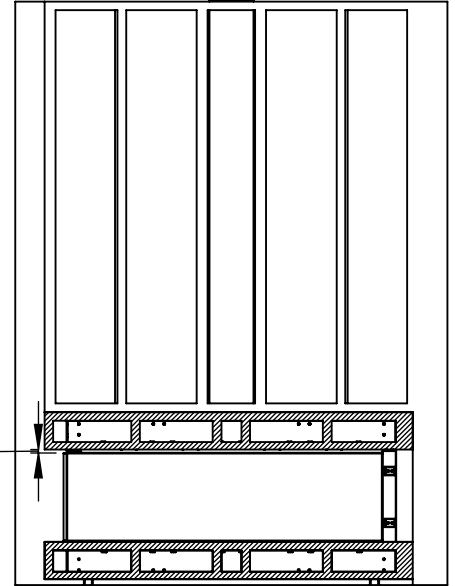

Last Step - Finishing The Fireplace Wall:

