

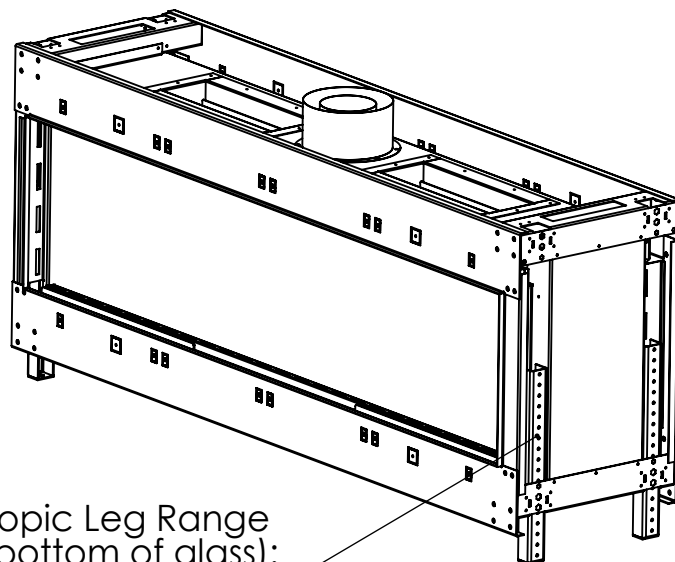

# FLARE See Through 70

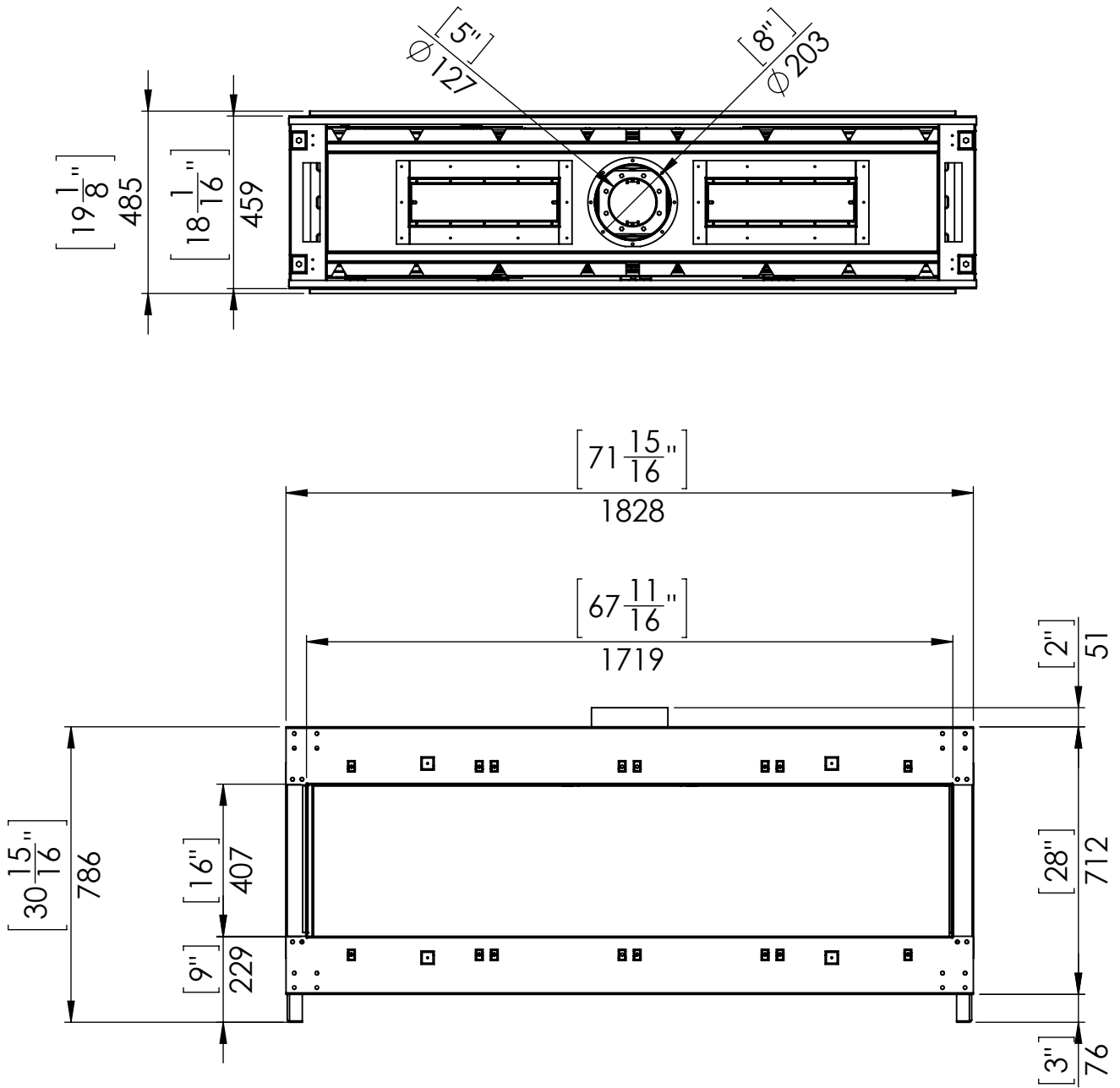

Telescopic Leg Range  
(from bottom of glass):  
9" - 19"

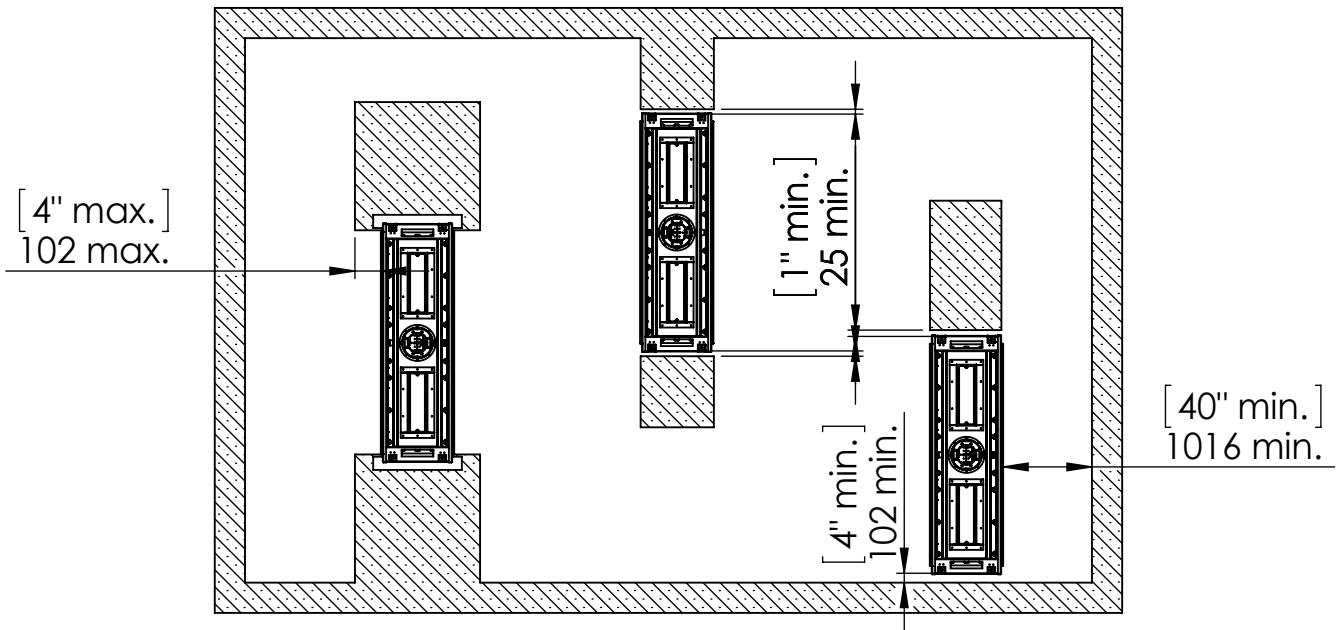

## Chimney Installation

### Horizontal Termination

For 5 x 8 vent size create 10" x 12" vent termination opening

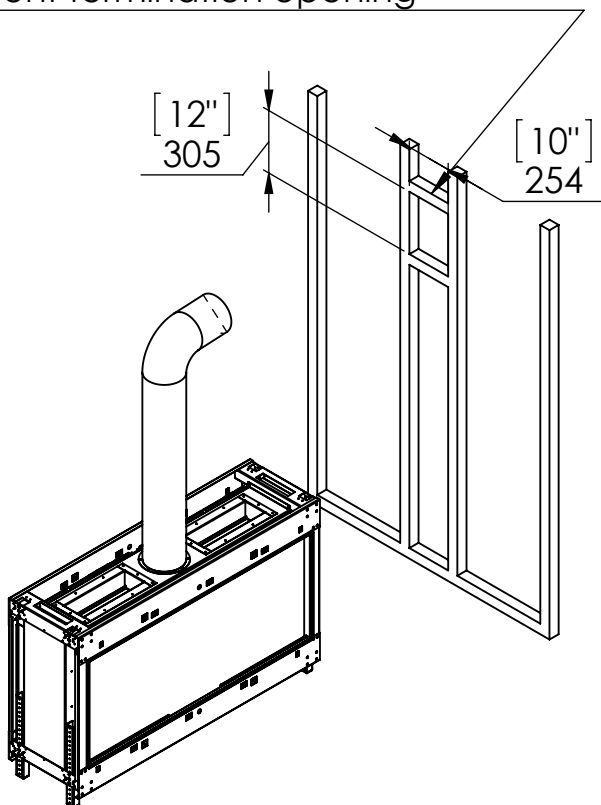

### Vertical Termination

For 5 x 8 vent size create 10" x 10" vent termination opening

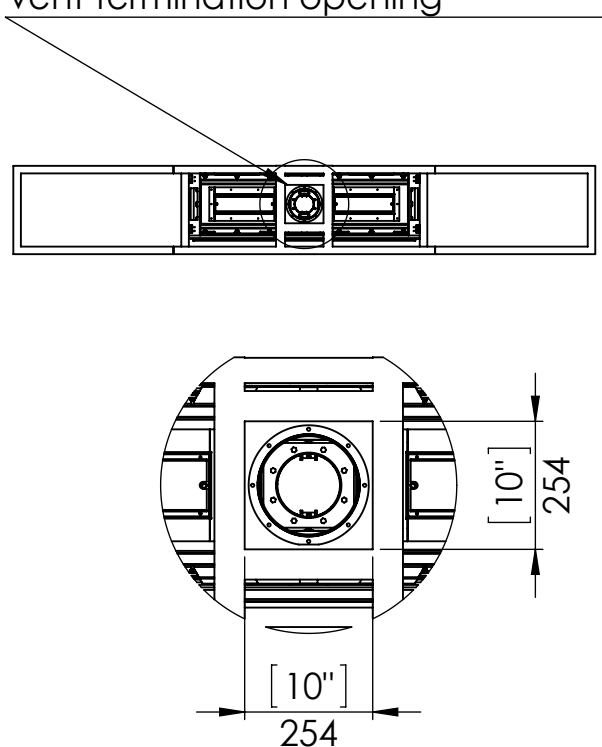

## Flat Installation

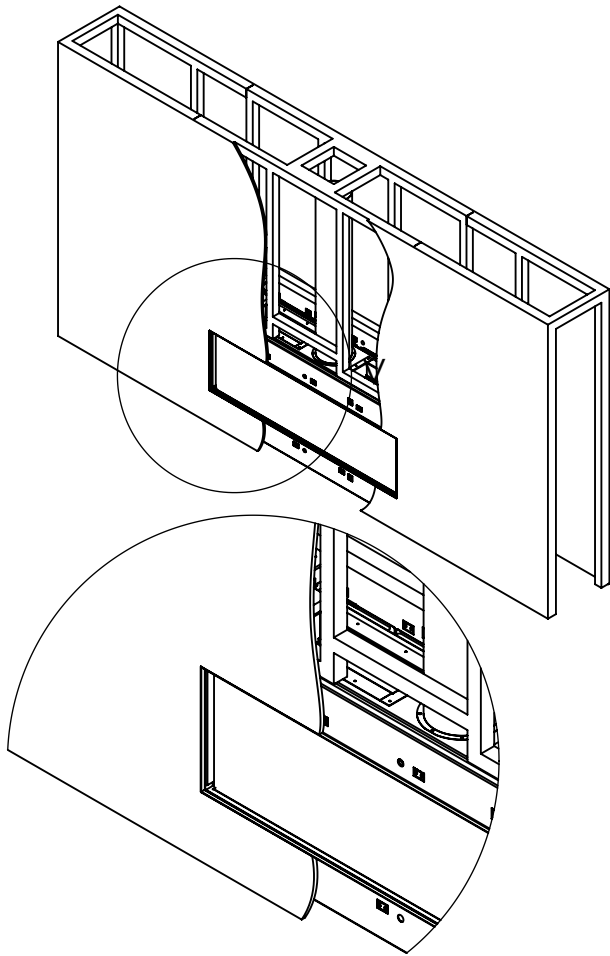

## L Shape Installation

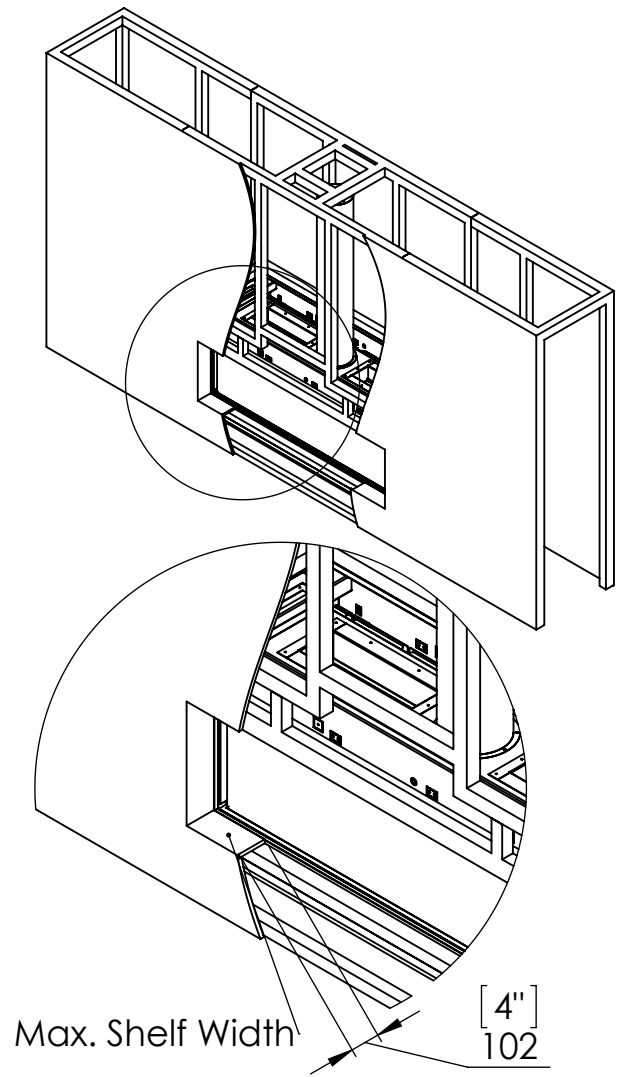

### Step 1 - Basic Framing :

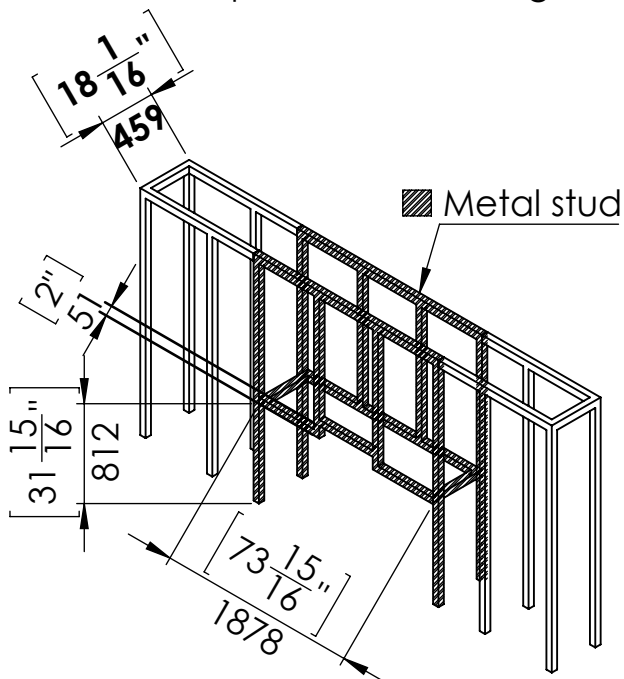

### Step 1 - Basic Framing :

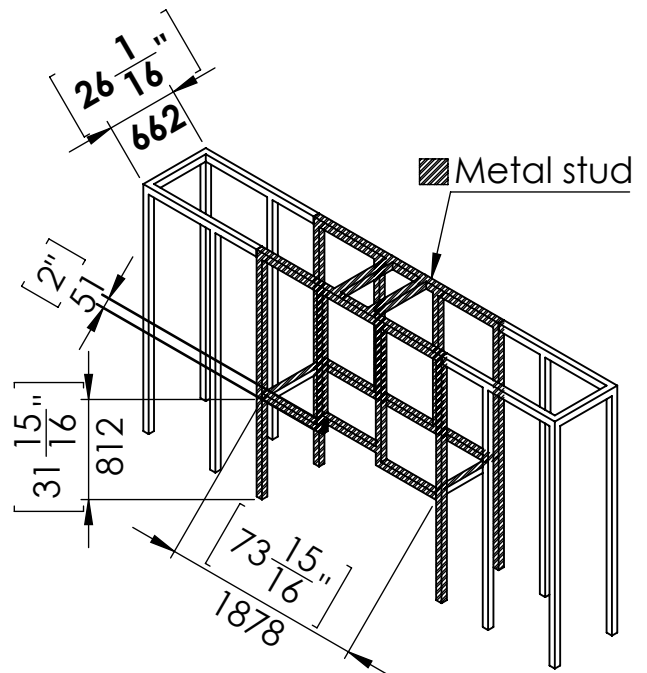

## Flat Installation

Step 2 -Positioning the Fireplace:

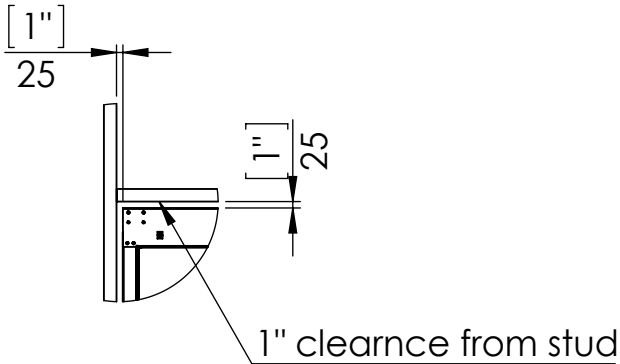
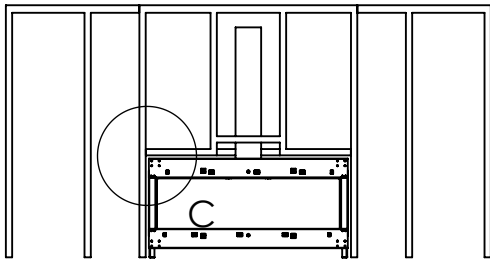
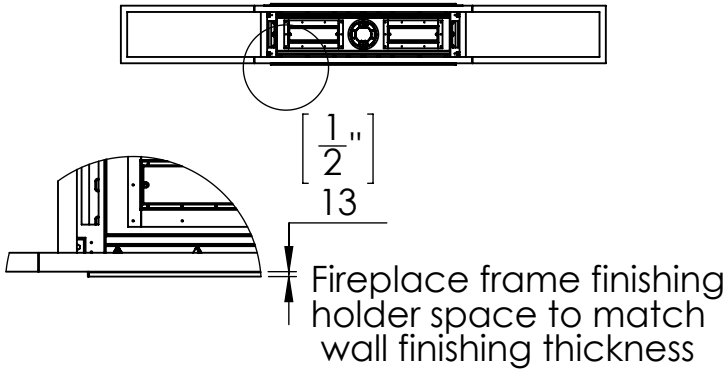

Last Step - Finishing The Fireplace Wall:

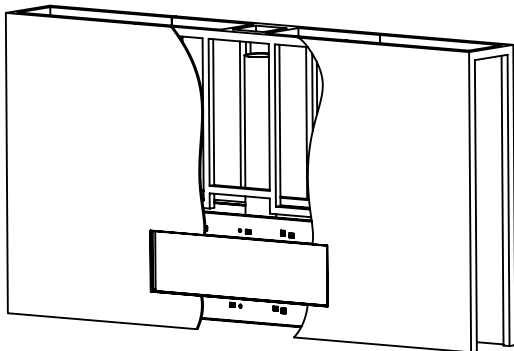

## L Shape Installation

Step 2 -Positioning the Fireplace:

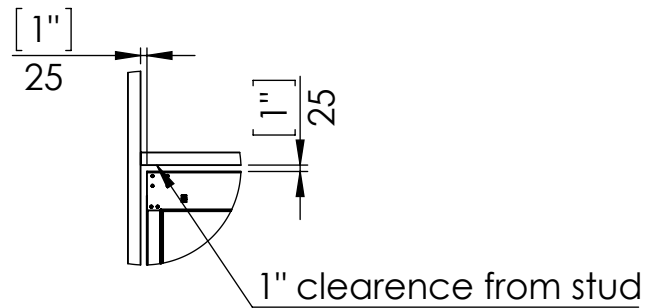
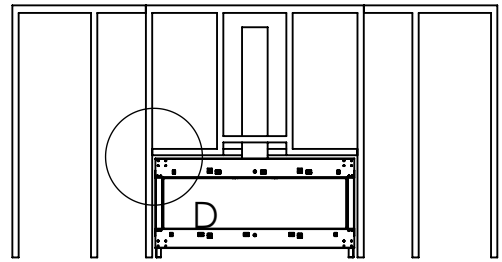
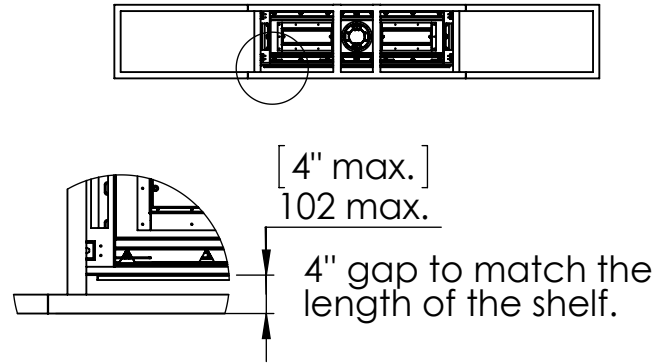

Step 3 - Framing Front Studs For L Shape:

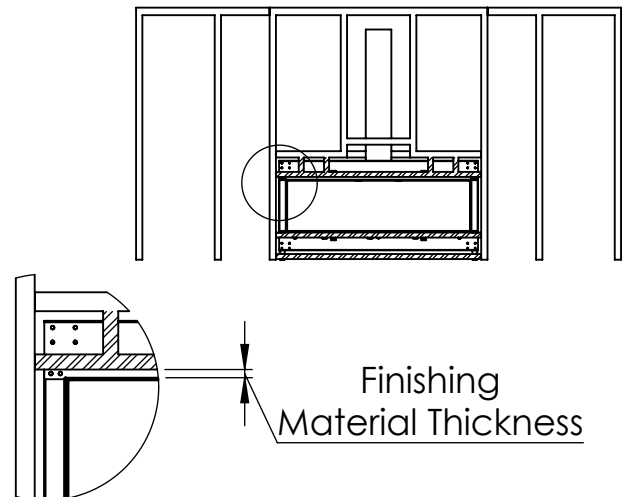

## L Shape Finishing Install

Last Step - Finishing The Fireplace Wall:

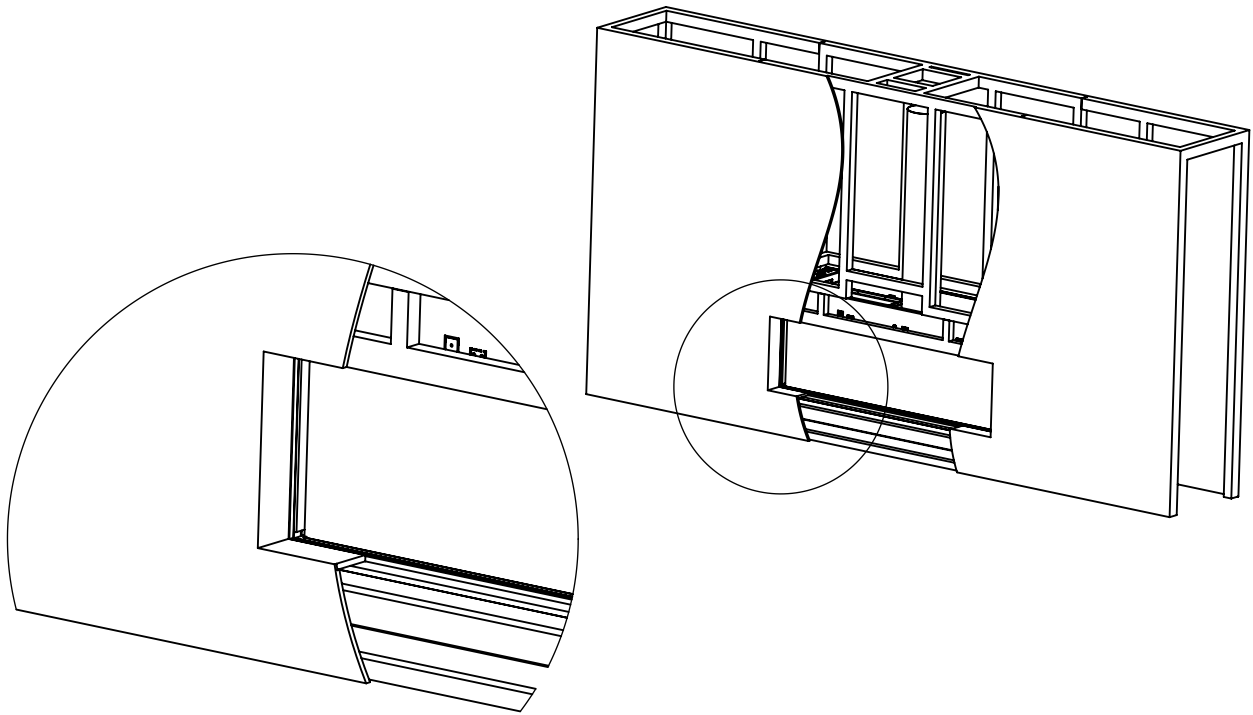

## Specifications for Appliance Flare See Through 70

Factor	NG	LPG
Burner Type	35,80,35	35,80,35
Orifice	550,800,550	160,180,160
BTU Max.	52200	43000
BTU min.	28000	20000
Kw/h	15.3k	12.6k
Chimney DIA.	5X8	5X8
Manifold Pressure[w.c]	3.4	8.8
Efficiency rate	82	79
Glass Size Length\Width	1700 X 420 mm	66" 15/16 X 16" 9/16'
Appliance Weigh	195Kg	430lb